

**JUNIOR**

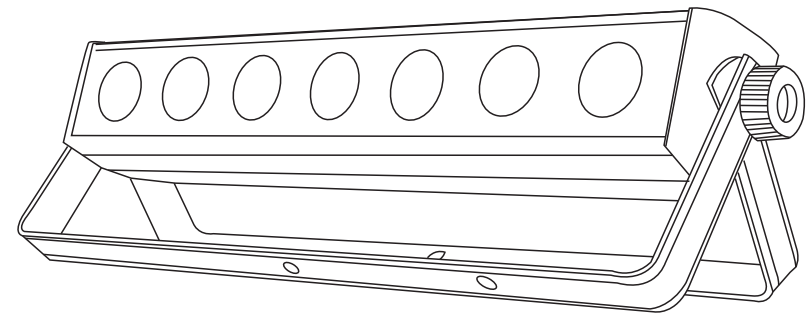

**JNR BAR 7\*30**  
**JNR-8021**

PR LIGHTING LTD.  
<http://www.pr-lighting.com>  
1582 Xingye Avenue, Nancun Panyu  
Guangzhou, 511442 China  
TEL: +86-20-3995 2888

# 1 SAFETY INSTRUCTIONS



## CAUTION

Becareful with your operations. With a dangerous voltage you cansuffer a dangerous electric shock when touching wires!

This device has left the factory in perfect condition. In order to maintain this condition and to ensure a safe operation, it is absolutely necessary for the user to follow the safety instructions and warning notes written in this user manual.



## IMPORTANT

Damages caused by the disregard of this user manual are not subject to warranty. The dealer will not accept liability for any resulting defects or problems.

If the device has been exposed to temperature changes due to environmental changes, do not switch it on immediately. The arising condensation could damage the device. Leave the device switched off until it has reached room temperature.

This device falls under protection-class I. Therefore it is essential that the device be earthed.

The electric connection must carry out by qualified person.

The device shall only be used with rate voltage and frequency.

Make sure that the available voltage is not higher than stated at the end of this manual.

Make sure the power cord is never crimped or damaged by sharp edges. If this would be the case, replacement of the cable must be done by an authorized dealer.

Always disconnect from the mains, when the device is not in use or before cleaning it. Only handle the power cord by the plug. Never pull out the plug by tugging the power cord.

During initial start-up some smoke or smell may arise. This is a normal process and does not necessarily mean that the device is defective, it should decrease gradually.

Please don't project the beam onto combustible substances.

Fixtures cannot be installed on combustible substances, keep more than 50cm distance with wall for smooth air flow, so there should be no shelter for fans and ventilation for heat radiation.

If the external flexible cable or cord of this luminaire is damaged, it shall be exclusively replaced by the manufacturer or his service agent or a similar qualified person in order to avoid a hazard.

# 10 MAINTENANCE AND CLEANING

The following points have to be considered during the inspection:

- 1) All screws for installing the devices or parts of the device have to be tightly connected and must not be corroded.
- 2) There must not be any deformations on the housing, color lenses, fixations and installation spots (ceiling, suspension, trussing).
- 3) Mechanically moved parts must not show any traces of wearing and must not rotate with unbalances.
- 4) The electric power supply cables must not show any damage, material fatigue or sediments.

Further instructions depending on the installation spot and usage have to be adhered by a skilled installer and any safety problems have to be removed.



## CAUTION

Disconnect from mains before starting maintenance operation.



In order to make the lights in good condition and extend the life time, we suggest a regular cleaning to the lights.

- 1) Clean the inside and outside lens each week to avoid the weakness of the lights due to accumulation of dust.
- 2) Clean the fan each week.
- 3) A detailed electric check by approved electrical engineer each three month, make sure that the circuit contacts are in good condition, prevent the poor contact of circuit from overheating.

We recommend a frequent cleaning of the device. Please use a moist, lint- free cloth. Never use alcohol or solvents.

There are no serviceable parts inside the device. Please refer to the instructions under "Installation instructions".

Should you need any spare parts, please order genuine parts from your local dealer.

## 23CH Mode

Channel	Function	Value	Description
1	Total	0-255	RGB total dimming,from dark to light
2	Strobe	7-255	RGB strobe,speed from slow to fast
3	Red	0-255	1#Red dimming,from dark to light
4	Green	0-255	1#Green dimming,from dark to light
5	Blue	0-255	1#Blue dimming,from dark to light
6	Red	0-255	2#Red dimming,from dark to light
7	Green	0-255	2#Green dimming,from dark to light
8	Blue	0-255	2#Blue dimming,from dark to light
9	Red	0-255	3#Red dimming,from dark to light
10	Green	0-255	3#Green dimming,from dark to light
11	Blue	0-255	3#Blue dimming,from dark to light
12	Red	0-255	4#Red dimming,from dark to light
13	Green	0-255	4#Green dimming,from dark to light
14	Blue	0-255	4#Blue dimming,from dark to light
15	Red	0-255	5#Red dimming,from dark to light
16	Green	0-255	5#Green dimming,from dark to light
17	Blue	0-255	5#Blue dimming,from dark to light
18	Red	0-255	6#Red dimming,from dark to light
19	Green	0-255	6#Green dimming,from dark to light
20	Blue	0-255	6#Blue dimming,from dark to light
21	Red	0-255	7#Red dimming,from dark to light
22	Green	0-255	7#Green dimming,from dark to light
23	Blue	0-255	7#Blue dimming,from dark to light

## 2 UNPACKING

Thank you for choosing our JNR BAR 7\*30. For your own safety, please read this manual before installing the device. This manual covers the important information on installation and applications. Please install and operate the fixture with following instructions. Meanwhile, please keep this manual well for future needs.

The JNR BAR 7\*30 is made of a new type of high temperature strength of aluminum casing with nice outlook. The fixture is designed and manufactured strictly following CE standards, complying with international standard DMX512 protocol. It's available independently controlled and linkable with each other for operation. And it is applicable for large-scale live performances, theater, studio, nightclubs and discos.

The JNR BAR 7\*30 adopts 7PCS 30W 3-IN-1 LEDs (RGB) which features high brightness and stability. Please carefully unpack it when you receive the fixture and check whether it is damaged during the transportation. And please check whether the following items are included inside the box:

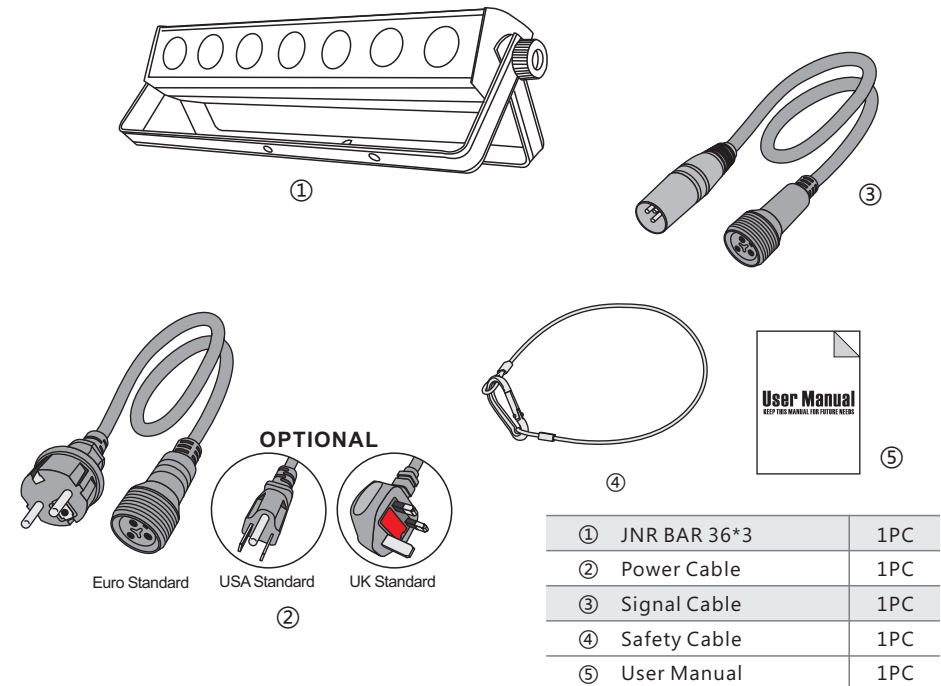

### 3 FEATURES & SPECIFICATIONS

#### Features

- 7\*30W tri color LEDs (RGB in one)
- 16.7 Millions of colors mixable
- 50,000 hours life span and lower power consumption
- Stunning light output with high intensity and high color rendering index
- 0-100% Smooth linear electronic dimmer
- Flicker free control capability
- 25T/s high speed LED shutter/strobe effect with variable speed
- Dynamic macro effect with variable speed
- 12 Internal color running programs, available for strobe effect to gether
- 13 DIY internal color running programs with background.
- Foreground colors changeable, available for strobe effect to gether
- DMX512, master-slave and sound activated controllable or auto operation
- Rugged, die cast aluminum alloy, compact and light weight
- Noise free natural cooling system
- Front window with tempered glass
- 2 Multi-positioning brackets for floor projection or hanging projection
- Manual TILT angle adjustment
- 4-Button red LED display
- IP20 rated lockable power connectors IN/OUT
- IP20 rated lockable 3-pin XLR DMX connectors IN/OUT
- -45°C to 45°C operation temperature
- IP20 protection rating

#### Specifications

**Input Voltage:** AC90-260V 50/60Hz

**LED Quantities:** 7PCS 30W 3-IN-1 LEDs (RGB)

**Control Signal:** DMX512, master-slave and sound activated or auto operation

**Control Channel:** 2/3/5/8/21/23 DMX Channels

**Power Consumption:** 135W

**Dimensions:** 500(W)\*85(D)\*140(H)mm

**Packing Dimensions:** 700(W)\*180(D)\*245(H)mm

**Net Weight:** 3.2kg

**Gross Weight:** 4.1kg

#### 21CH Mode

Channel	Function	Value	Description
1	Red	0-255	1#Red dimming,from dark to light
2	Green	0-255	1#Green dimming,from dark to light
3	Blue	0-255	1#Blue dimming,from dark to light
4	Red	0-255	2#Red dimming,from dark to light
5	Green	0-255	2#Green dimming,from dark to light
6	Blue	0-255	2#Blue dimming,from dark to light
7	Red	0-255	3#Red dimming,from dark to light
8	Green	0-255	3#Green dimming,from dark to light
9	Blue	0-255	3#Blue dimming,from dark to light
10	Red	0-255	4#Red dimming,from dark to light
11	Green	0-255	4#Green dimming,from dark to light
12	Blue	0-255	4#Blue dimming,from dark to light
13	Red	0-255	5#Red dimming,from dark to light
14	Green	0-255	5#Green dimming,from dark to light
15	Blue	0-255	5#Blue dimming,from dark to light
16	Red	0-255	6#Red dimming,from dark to light
17	Green	0-255	6#Green dimming,from dark to light
18	Blue	0-255	6#Blue dimming,from dark to light
19	Red	0-255	7#Red dimming,from dark to light
20	Green	0-255	7#Green dimming,from dark to light
21	Blue	0-255	7#Blue dimming,from dark to light

### 8CH Mode

Channel	Function	Value	Description
1	Total	0-255	RGB total dimming,from dark to light
2	Strobe	7-255	RGB strobe,speed from slow to fast
3	Effect	0-5	Null
		6-15	Customize effect 1#--13#
		16-25	CH1:Dimming
		26-35	CH2:Superimposed strobe effect
		36-45	CH5:Select background colors
		46-55	CH6-CH8:Select effect colors
		56-65	
		66-75	
		76-85	
		86-95	
		96-105	
		106-115	
		116-125	
		126-135	
		136-145	Jump effect 1
		146-155	Jump effect 2
		156-165	Jump effect 3
		166-175	Jump effect 4
		176-185	Jump effect 5
		186-195	Jump effect 6
196-205	Jump effect 7		
206-215	Jump effect 8		
216-225	Loops jump effect 1 to 8		
226-235	Yellow shade effect		
236-245	Loops red to yellow shade effect		
246-255	Sound active		
4	Effect speed	0-255	Effect speed from slow to fast
5		0-255	
6	Red	0-255	Red dimming,from dark to light
7	Green	0-255	Green dimming,from dark to light
8	Blue	0-255	Blue dimming,from dark to light

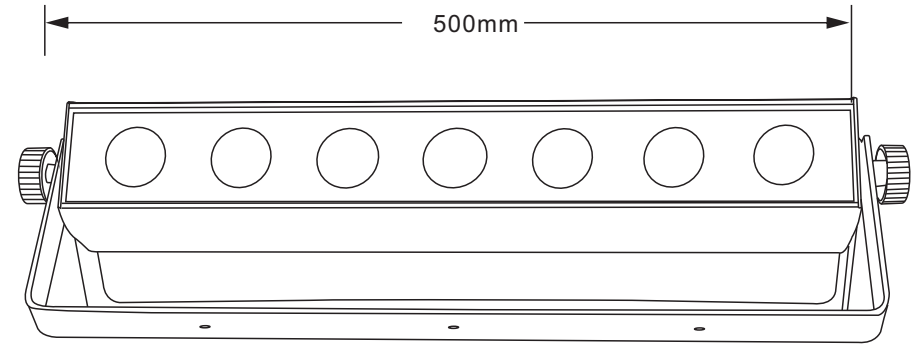

## 4 PHOTOMETRIC DATA

■ Photometric Beam Angle Data  $25^\circ$  Beam Angle  $LUX \times 0.0929=FC$

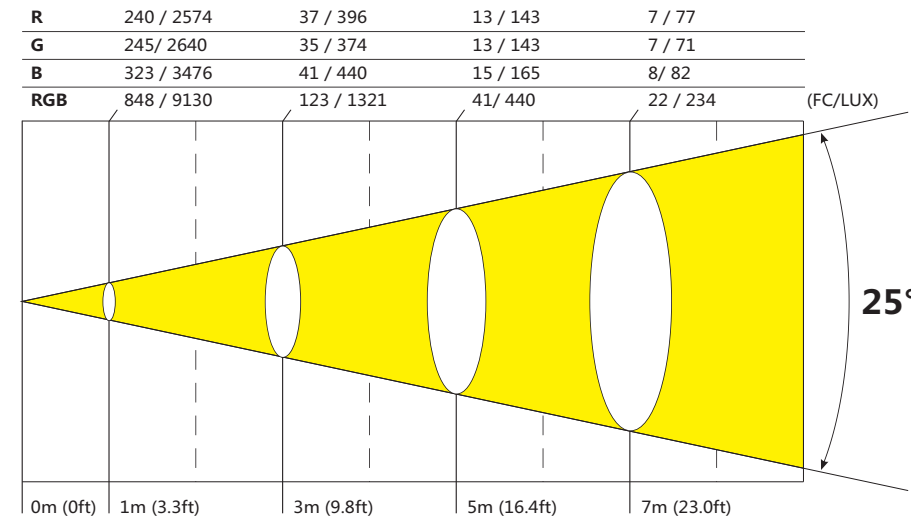

## 5 OPERATION INSTRUCTIONS

- The JNR BAR 7\*30 is for wash effect for on-site decoration purpose.
- Don't turn on the fixture if it's been through severe temperature difference like after transportation because it might damage the light due to the environment changes. So make sure to operate the fixture until it is in normal temperature.
- This light should be keep away from strong shaking during any transportation or movement.
- Don't pull up the light by only the head, or it might cause damages to the mechanical parts.
- Don't expose the fixture in overheat, moisture or environment with too much dust when installing it. And don't lay any power cables on the floor. Or it might cause electronic shock to the people.
- Make sure the installation place is in good safety condition before installing the fixture.
- Make sure to put the safety chain and check whether the screws are screwed properly when installing the fixture.
- Make sure the lens are in good condition. It's recommended to replace the units if there are any damages or severe scratch.
- Make sure the fixture is operated by qualified personnel who knows the fixture before using.
- Keep the original packages if any second shipment is needed.
- Don't try to change the fixtures without any instruction by the manufacturer or the appointed repairing agencies.
- It is not in warranty range if there are any malfunctions from not following the user manual to operate or any illegal operation, like shock short circuit, electronic shock, lamp broke, etc.

## 9 DMX CHANNELS

### 2CH Mode

Channel	Function	Value	Description
1	Color Effect	0-5	Null
		6-16	Red
		17-27	Green
		28-38	Blue
		39-49	Yellow
		50-60	Pink
		61-71	Cyan
		72-82	White
		83-93	Jump effect 1
		94-104	Jump effect 2
		105-115	Jump effect 3
		116-126	Jump effect 4
		127-137	Jump effect 5
		138-148	Jump effect 6
		149-159	Jump effect 7
		160-170	Jump effect 8
		171-181	Loops jump effect 1 to 8
		182-192	Red shade effect
193-203	Green shade effect		
204-214	Blue shade effect		
215-225	Pink shade effect		
226-236	Yellow shade effect		
237-247	Loops red to yellow shade effect		
248-255	Sound active		
2	Speed	0-255	Speed from slow to fast

### 3CH Mode

Channel	Function	Value	Description
1	Red	0-255	Red dimming, from dark to light
2	Green	0-255	Green dimming, from dark to light
3	Blue	0-255	Blue dimming, from dark to light

### 5CH Mode

Channel	Function	Value	Description
1	RGB	0-255	RGB total dimming, from dark to light
2	Red	0-255	Red dimming, from dark to light
3	Green	0-255	Green dimming, from dark to light
4	Blue	0-255	Blue dimming, from dark to light
5	Strobe	7-255	RGB strobe, speed from slow to fast

## 8 MENU OPERATIONS

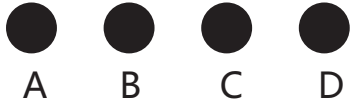

**A:**Table1 function loops add;

**B:**Function value add;

**C:**Function value decrease;

**D:**Save the setting

No.	Show	Value	Function
1	d001	001-512	DMX512 address,2channel mode
2	1d01	ID01-ID99	Convenient 42 channels mode DMX512 address set. ID1: DMX512 address is 001(42 channels mode); ID2:DMX512 address is 043(42 channels mode); ...
3	r255	0-255	Red dimming,from dark to light
4	G255	0-255	Green dimming,from dark to light
5	b255	0-255	Blue dimming,from dark to light
6	FF99	00-99	RGB strobe,speed from slow to fast
7	1JPD	0-9	Jump effect 01,speed from slow to fast
8	2JPD	0-9	Jump effect 02,speed from slow to fast
9	3JPD	0-9	Jump effect 03,speed from slow to fast
10	4JPD	0-9	Jump effect 04,speed from slow to fast
11	5JPD	0-9	Jump effect 05,speed from slow to fast
12	6JPD	0-9	Jump effect 06,speed from slow to fast
13	7JPD	0-9	Jump effect 07,speed from slow to fast
14	8JPD	0-9	Jump effect 08,speed from slow to fast
15	9JPD	0-9	Loops jump effect 01 to 08
16	1dED	0-9	Red shade effect,Speed from slow to fast
17	2dED	0-9	Green shade effect,Speed from slow to fast
18	3dED	0-9	Blue shade effect,Speed from slow to fast
19	4dED	0-9	Pink shade effect,Speed from slow to fast
20	5dED	0-9	Yellow shade effect,Speed from slow to fast
21	6dED	0-9	Loops red to yellow shade effect,Speed from slow to fast
22	5LdD		Sound active,Speed from slow to fast
23	CH02	02/03/05/08 /21/23	DMX channel mode set

## 6 INSTALLATIONS

**Wall or architecture projections:** You could just install the JNR BAR 7\*30 near below the wall, projecting angles adjustable with any angles suitable for on-site requirements.

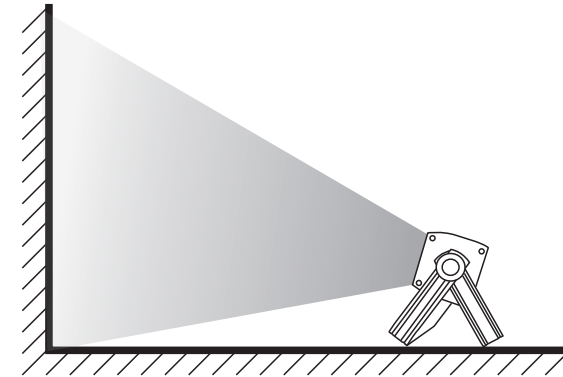

## 7 DMX-512 CONTROL CONNECTIONS

Connect the provided XLR cable to the female 3-pin XLR output of your controller and the other side to the male 3-pin XLR input of the architectural. You can chain multiple

Architectural together through serial linking. The cable needed should be two core, screened cable with XLR input and output connectors. Please refer to the diagram below.

DMX-512 connection with DMX terminator.

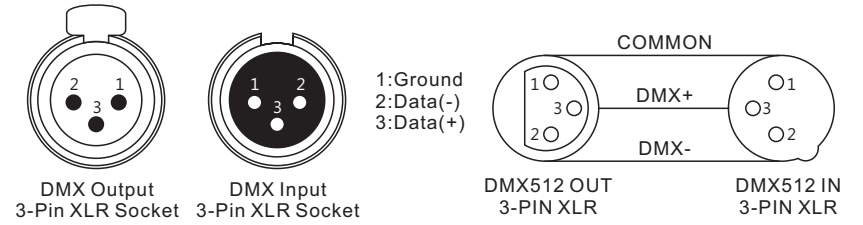
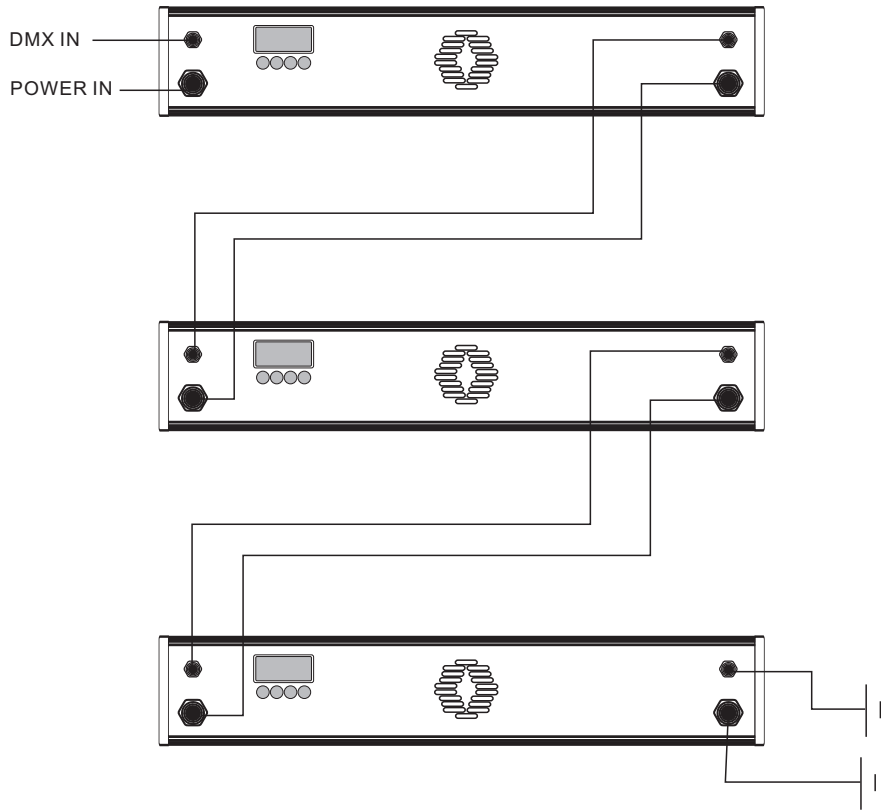
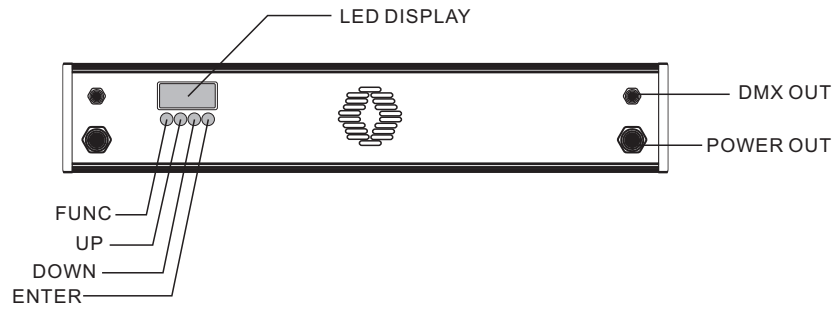

For installations where the DMX cable has to run a long distance or is in an electrically noisy environment, such as in a discotheque, it is recommended to use a DMX terminator. This helps in preventing corruption of the digital control signal by electrical noise. The DMX terminator is simply an XLR plug with a 120 Ω resistor connected between pins 2 and 3, which is then plugged into the output XLR socket of the last fixture in the chain. Please see illustrations below.

