

PR-6000 Wash/Framing(1400W)

PR-2926

The user manual contains important information about the safe installation and use of a projector. Please read and follow these instructions carefully and keep the manual in a safe place for future reference.

PR LIGHTING LTD.
<http://www.pr-lighting.com>

INDEX

1.	SAFETY AND WARNINGS.....	3
2.	INSTRUCTIONS.....	4
3.	APPEARANCE.....	5
	...	
4.	INSTALLATION.....	5
5.	SETUP AND CONFIGURATION.....	8
6.	OPERATION MENU.....	10
7.	DMX PROTOCOL.....	12
8.	SIGNS ON THE TOUCH SCREEN.....	19
9.	ERROR MESSAGE.....	19
10.	TECHNICAL DATA.....	20
11.	CIRCUIT DIAGRAM.....	23
12.	COMPONENT ORDER CODES.....	25
	APPENDIX.....	26
	...	

ACCESSORIES

The following items are supplied with the projector and please check:

Name	Quantity	Unit	Remark
Clamps	2	Pcs	
XLR Connectors	1	Set	Male and female
Safety cord	2	Pc	
User manual	0	Pc	QR Code

Please note that as part of our ongoing commitment to continuous product development, specifications are subject to change without notice. Whilst every care is taken in the preparation of the manual we reserve the right to change specifications in the course of product improvement. The publishers cannot be held responsible for the accuracy of the information herein, or any consequence arising from them.

Every unit is tested completely and packed properly by the manufacturer. Please make sure the packing and / or the unit are in good condition before installation and use. Should there be any damage caused by transportation, consult your dealer and do not use the unit. Any damage caused by improper use will not be assumed by the manufacturer and / or dealer.

Any future technical change in the user manual won't be with any notice.

Note: For the products made by Guangzhou PR lighting Ltd, the warranty for the whole product is one year starting from the delivery date but the light source is not within the warranty







1. SAFETY AND WARNINGS



NOTE

Before a projector's installation, power-on, operation and maintenance, please carefully read the safety information hereinafter!

The following safety signs are used in the user manual.

						
Warning	User Manual	Electrical shock	Goggles	Protective Gloves	Flames	High Temperature



- When unpacking, check if there is transportation damage before using the projector. Should there be any damage caused by transportation, consult your dealer and do not use it.
- The manufacture is not responsible for loss caused by the user not following the manual or changing the projector as he/she likes.
- Please be noted that the damage caused by changing the projector at will is not warranted.
- Do not hesitate to contact the dealer or the manufacturer if any questions or advice.



- The projector is for indoor use only, IP20.
- Use only in dry locations. Keep this unit away from rain and moisture, excessive heat, humidity and dust. Do not allow contact with water or any other liquids.
- The projector should be kept away from high temperature, fire, electrical surge, vibration and strong light while being operated.
- The projector is only intended for installation, operation and maintenance by qualified personnel. And the operation must strictly follow the procedures in the manual.
- The projector is not for a user for any replacements and the user shouldn't open the projector for repair and maintenance.



- Don't look straightly into the light sources especially for epileptics, otherwise eyes will be burned.
- Do not connect this device to any type of dimmer pack.
- If the lamp, lens and screen protective cover of the a lighting fixture have obvious damage, i.e., to the extent that it hurts the performance like cracking or deformation. Please stop use it and replace them with the original parts, otherwise its performance will be compromised.
- For the location of a lighting fixture, it shouldn't be seen in the distance of less than 4 meters.



- Before operation, please confirm that all covers(housing) are on and screws tightened. It's forbidden to use a projector while covers(housing)are off.
- Keep the lamp clean and do not touch it with bare hands.
- While operating it, wear protective items.



- Any electrical connection must be carried out by a qualified person.
- Before installation, please confirm the voltage supplied matches what is required for the projector.
- Each projector must be properly earthed and installed as per related electrical standards.
- Do not use power cord with its insulator damaged and connect the power cord with other cables.
- If the projector is not used or under cleaning,, please hold the plug and unplug it. Do not unplug it forcefully or by pulling the power cable.
- All power cords must conform to related safety and regulations.
- While being operated, the projector should not be under rains or in humidity.
- Do not switch on and off the projector constantly in very short intervals, otherwise the light source's and other

electrical parts' life will be shortened .



- There are safety cord holes at the bottom of the base of a projector. In view of safety, please run the safety cord supplied through the safety cord holes for safety support.
- Before any installation, maintenance and cleaning work, please ensure the projector is disconnected from power mains.



•After running for 5 minutes, the temperature of the housing of the projector is 80°C. After stable operation , its temperature is 170°C.

•While the lamp is stricken for the first time, there will be smoke and strange smell. It's normal and does not mean the projector has some defects.

• While a lighting fixture works properly under normal ambient temperature, the maximum temperature of the external surface of the control device(The integrated control device means the external surface of the housing of the lighting fixtures electric chamber)allowed is 75 Celsius degrees.



•Do not mount the projector directly on inflammable surface.

•Do not project the beam straightly on combustibile items and the minimum distance between the projector and illuminated items is 18m.

•A projector should be installed with good ventilation and the minimum distance between the projector and walls is 50cm. At the same time, please ensure the fans and air inlets and outlets are workable.

2. INSTRUCTIONS

•CLEANING AND MAINTENANCE

If a projector can't start. Please check if the fuse is blown up. If it does, replace it with a new fuse with same ratings. And the projector has over-temperature protective device. If the temperature is too high, the protective device will be triggered to shut the projector off. When it happens, please check if the fans run normally or fan shield is blocked by dust. After the issue is solved, restart the projector.

The accumulation of oil, smoke and dust on the lens will compromise the light output. Cleaning a projector is very necessary to ensure a reliable use of it. Cooling fans need to be cleaned every 15days. Internal lens, reflector and hot mirror need to be cleaned periodically to optimize light output.

Cleaning frequency is to be decided by operations and its environment. Use soft cloth and normal detergent for glass for cleaning work. It's advised external optical system be cleaned every 20days and internal optical systems every 30/60days. Keep lens clean and do not touch optical parts with bare hands.



- Before any maintenance and cleaning, please ensure the project is off the power.
- Only qualified person is allowed to do maintenance.
- During maintenance and before maintenance, the projector must be off power.



•To avoid sunlight or other light penetrating into the head via the front lens, resulting in high temperature internally causing damages to the projector. Before power-off, please use Tilt channel to move the head and make it facing downward.

- Do not use alcohol or other organic solvent to clean the housing to avoid damage.
- Do not use any solvent with chemical elements to clean color filters or hot mirror.

•LUBRICATION

To ensure smooth movement of gobos and zoom and focus lens, it's advised rotators' bearings and 2 sliding bars for zoom and focus lens be lubricated every 2 months. High quality and high temperature lubricant/grease is advised..

.TROUBLESHOOTING

PROBLEM	ACTION
The projector doesn't switch on	<ul style="list-style-type: none"> ➤ Check the fuse on the power socket. ➤ Check the lamp.
The lamp is on but the projector doesn't respond to the controller	<ul style="list-style-type: none"> ➤ Make sure that the fixture's start address is right ➤ Replace or repair the XLR signal cable.
The projector functions intermittently	<ul style="list-style-type: none"> ➤ Make sure the fan is working well or fans and their shields are not blocked
Beam appears dim, Low in brightness	<ul style="list-style-type: none"> ➤ Make sure the lamp is within its lifespan ➤ Remove dust or grease from the lenses.
The project image appears to have a halo	<ul style="list-style-type: none"> ➤ Carefully clean the lamp, optical lenses and other components.
Heavily Defective Beam	<ul style="list-style-type: none"> ➤ Check if lens are in good condition(not cracked) ➤ Clean dust or grease on the lens.

3.APPEARANCE

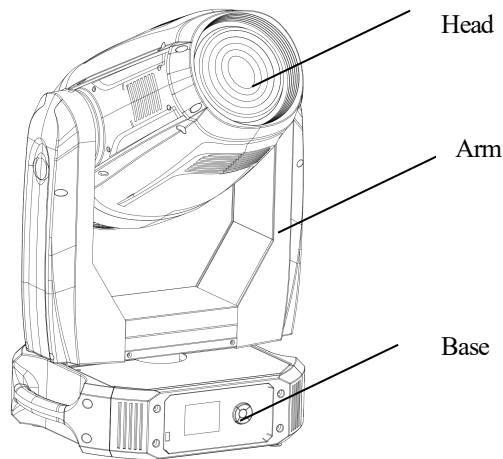

4.INSTALLATION

.RIGGING

Before moving a projector, Please lock Pan and Tilt. Before its operation, please unlock them. It's forbidden to run a projector with power while it is locked

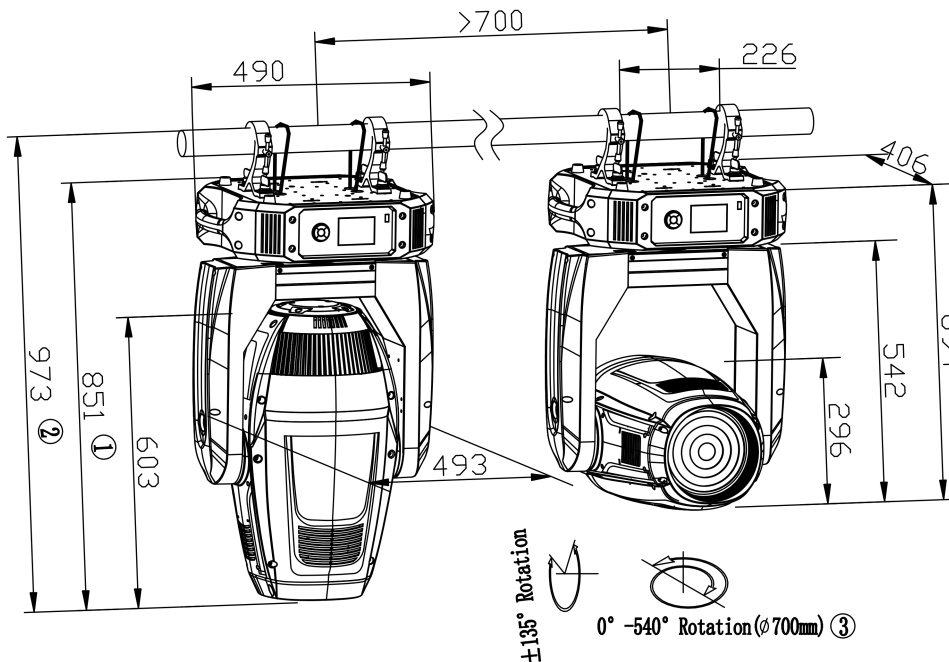

Note:

1. the distance between the foot of the base and the front lens cover(the head facing downward)
2. the distance between mounting truss and the front lens cover(the head facing downward)
3. The maximum diameter of the rotating head (minimum spacing between fixtures)

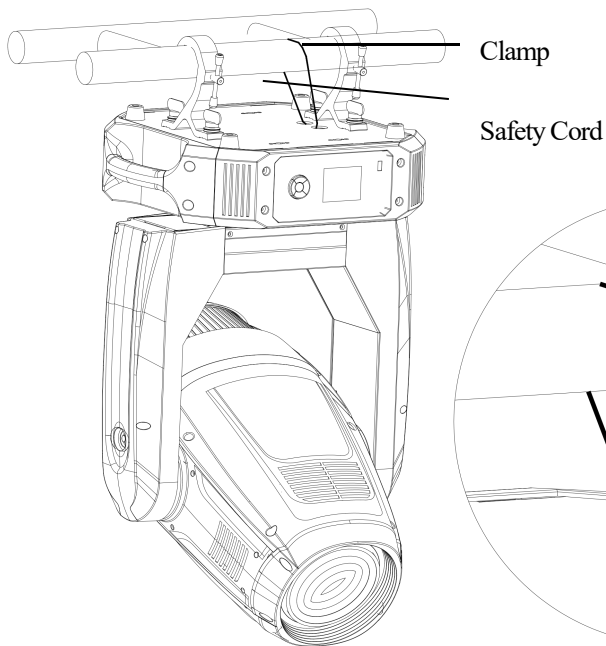

Warning!
Please run the safety cord through 4 safety cord holes for safety

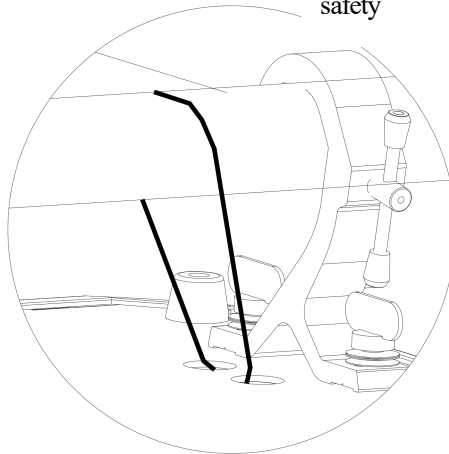

Take 2 clamps and the safety cord out from the package and mount 2 clamps on the underside of fixture with 2 retainers attached to each clamp. Hang the fixture on the structure and fasten the screws attached to each clamp. (See the **WARNING** on the underside of the base as shown above) **To pass the SAFETY CORD through the HOLES for safety!** Always ensure that the projector is firmly anchored to avoid vibration and slipping whilst functioning. Always ensure that the structure that you are going to mount the projector to is secure and strong enough to support the weight of the unit.



WARNING:

- The projector **MUST** be lifted or carried by the **HANDLES** instead of clamps.
- For safety the safety cord should afford 10 times the Projector's weight.

• POWER CONNECTION

Connect the power cord as follows:

- L (live) =brown
- E (earth) =yellow/green
- N (neutral) =blue

Before power connection, please ensure the power supplied must match what the nameplate says. It is recommended that each projector be connected with power separately so that they may be individually switched on and off.



- The earth wire(yellow/green) must be connected to the ground. And electrical connection must be in accordance with the standards concerned.
- If any questions about the electrical installation, do not continue but consult a qualified electrician.

•DMX CONTROL CONNECTION:

5-PIN

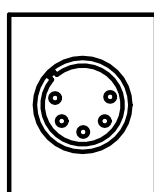

DMX OUT

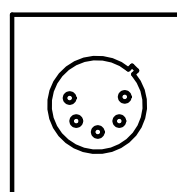
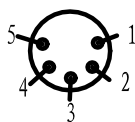

DMX IN

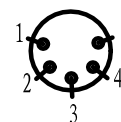

DMX 512	
PIN	FUNCTION
1	GND
2	DATA-
3	DATA+
4	N/C
5	N/C

Connection between controller and projector and between one projector and another must be made with a twin-screened cable, with each wire having at least a 0.5mm in diameter. Connection to and from the projector is via cannon 5 pin (which are included with the projector) or 5 pin XLR plugs and sockets. The XLR's are connected as shown in the figure above.

Note: care should be taken to ensure that none of the pins touch the metallic body of the plug or each other. XLR plugs and sockets mustn't be connected in any way other than mentioned in the above figure. The Fixture accepts digital control signals in protocol DMX512 (1990).

Connect the controller's DMX output to the first fixture's DMX input, and connect the first fixture's DMX output to the second fixture's DMX input and connect the rest fixtures in the same way. Eventually connect the last fixture's DMX output to a DMX terminator as shown in the figure below.

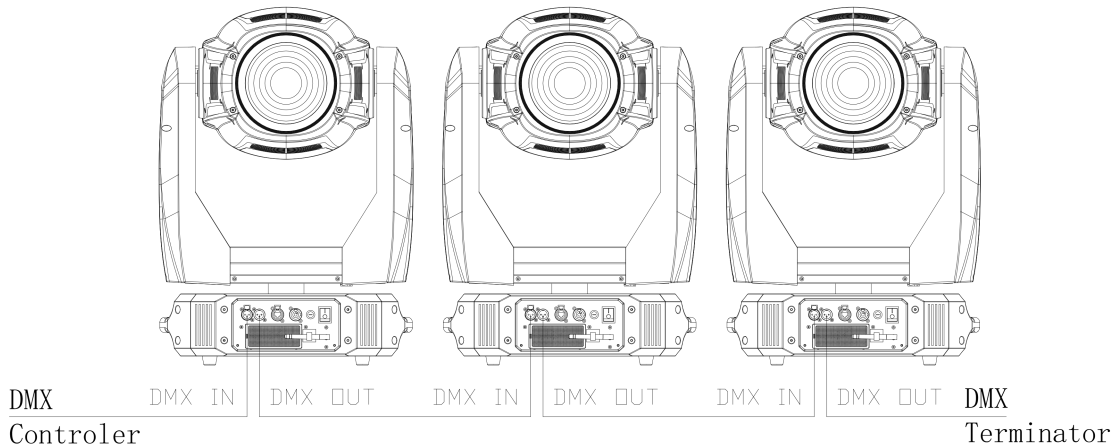

DMX TERMINATOR

In the Controller mode, at the last fixture in the chain, the DMX output has to be connected with a DMX terminator. This prevents electrical noise from disturbing and corrupting the DMX control signals.

The DMX terminator is simply an XLR connector with a 120Ω (ohm) resistor connected across pins 2 and 3, which is then plugged into the output socket on the last projector in the chain. The connections are illustrated below.

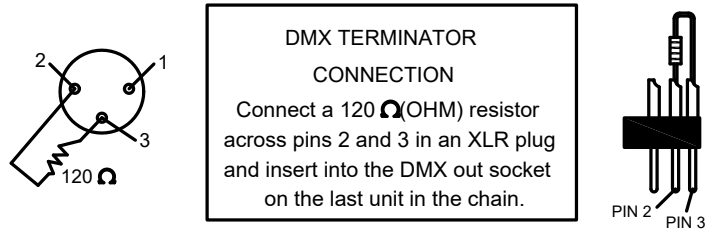

ALIGNMENT/INSTALLATION/REPLACEMENT OF A LAMP

Before installation/replacement/alignment of a lamp, disconnect the unit from the power and let it cool first.

Lock Tilt in the figure below and open the lamp cover after its 4 screws are loosened.

After removal of the lamp cover, take out the lamp while the 2 screws at both ends of the lamp are loosened.

Insert a new lamp. Note: while placing a new lamp, do not touch the burner of the lamp with bare hands, otherwise the light output will be compromised.

Fasten the 4 fast-fit screws after the lamp cover is on

Important: The unit uses high voltage discharge lamp with external igniter(⚠). While using the lamp, please carefully read "INSTRUCTIONS" packed with the lamp.

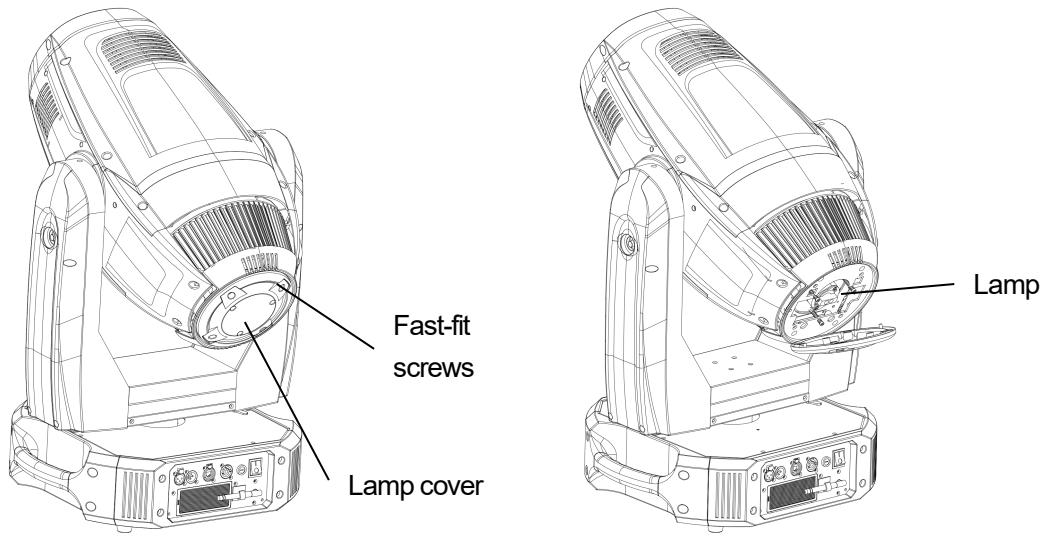

- Don't touch the internal surface of the reflector and the burner of the lamp with bare hands so as not to impair the beam output. While lamp's installation, do not damage the metal wire around the burner.
- Please read "Instructions " enclosed with the lamp
- Do operate the projector while adjusting the lamp

5.SETUP AND CONFIGURATION

•FRONT PANEL OPERATION

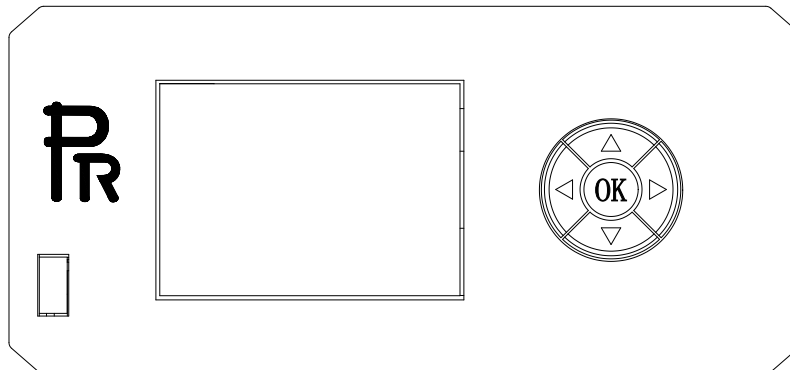

The projector configuration can be set conveniently via push buttons and color touch screen.

To browse through or change the projector's settings, touch the white area of the touch screen or press OK button for more than 3s(Only powered by the battery, pressing the OK button) to unlock the screen, then press key to enter the projector's function menus. Each main menu has its sub-menus. And each menu stands for special function. For the details, please see the following 6th point "Operation Menu":

1. At the page to set the fixture's functions, press , , , keys or their respective icons to select the functions desired.
2. While at 2nd, 3rd and 4th level of menus, the key is for ESCAPE, but key won't work, and key is used for ENTER. Press key to save the changes or enter into the sub menus. Press or keys to change the numbers(minus or plus). Or touch the option needed for change.

Shortcut keys: After the Function Menu is entered into, there are all options for the functions on the top of the screen. On the right there are 3 shortcut keys like , Lamp Control and English/Chinese.

• DMX START ADDRESS

Each projector must be given a DMX start address so that the correct projector responds to the correct control signals. This DMX start address is the channel number from which the projector starts to “listen” to the digital control information being sent out from the controller. The projector has 3 DMX modes. There are standard mode, short mode and extended mode. For example standard mode has 32 channels, so set the No. 1 projector’s address 001, No. 2 projector’s address 033, No. 3 projector’s address 065, No. 4 projector’s address 97, and so on.

Switch on the Projector . Press **OK** key more than 3 seconds to unlock panel, then press **▶** key to enter into the fixture’s operation menus.

Select DMX Address icon and press OK key or touch the icon directly on the display and select DMX address at the 2nd level menu for the address setting.

Press **▲** or **▼** keys or touch < , > displayed for the DMX address desired.

Press OK key to confirm.

Press the **◀** key to go back to the upper level menu.

• DMX WIRELESS CONTROL

The wireless control is optional. If fitted with wireless DMX module and the antenna, the fixture can achieve remote control and do as commanded.

The setup of it is below:

1. Press **OK** for more than 3s to unlock the control panel, then press **▶** key to enter into the operation menu and select “Config Settings”.
2. Select “Wireless First” or “Wireless Only” from the menu of “Signal Select”.

Only after the projector is linked with a transmitter, can it receive wireless signal sent by the transmitter. If unlinking it, Press “Enter” for the menu of Un-link Wireless under the upper level menu of Config Settings , then the fixture is unlinked with the wireless transmitter.

• STAND-ALONE MODE

Operate the projector without connecting with a controller, enable the master mode through the operation panel, the projector will run in Stand-Alone mode automatically.

DMX address can be set at any number within 512.

• MASTER/SLAVE MODE

Many projectors can run synchronously in the Master/Slave mode by linking them with each other. First, connect the first fixture’s DMX output to the second fixture’s DMX input using XLR-XLR control cable and then connect the second fixture’s DMX output to the third fixture’s DMX input, and so on until all projector are connected in this way. Eventually connect the last fixture’s DMX output to a DMX terminator. Set 1st projector as the master and others are Slaves.

Start Addresses of all Slaves are 001; Operation mode of the Master can be set any mode for a Master’ and Slaves’ operation mode can be set accordingly.

After Powered on, the group will run in Master/Slave Mode

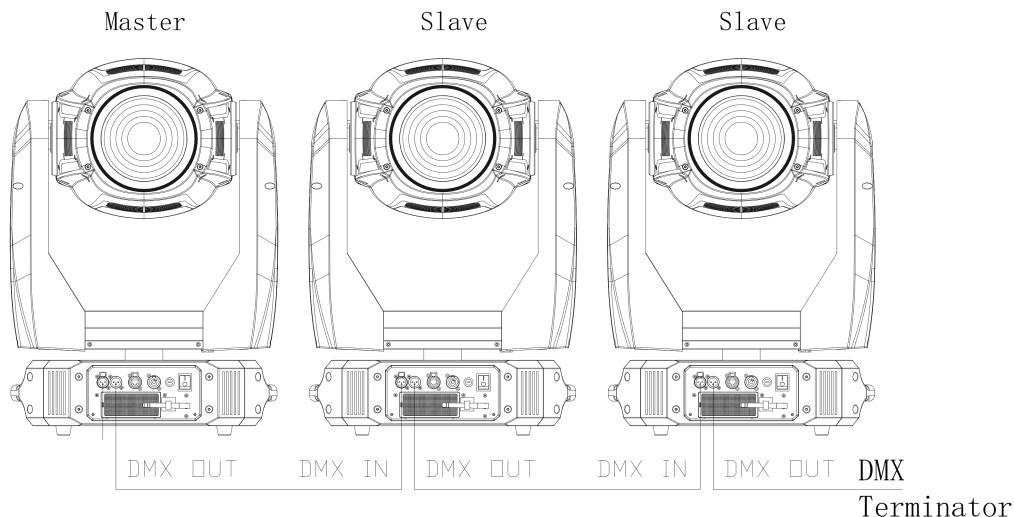

6. OPERATION MENU

1st LEVEL	2nd LEVEL	3rd LEVEL	4th LEVEL	5th LEVEL	
Address	DMX Address	1-486 (Short Mode) 1-481 (Standard Mode) 1-468 (Extended Mode)			
	IP Address	Default IP Address	2.X.X.X/10.X.X.X		
		Custom IP Address	X.X.X.X		
	SubNet Mask	X.X.X.X			
	ArtNet Universe	0-255			
sACN Universe	1-63999				
Reset	Total Reset	Really Reset?			
	Pan&Tilt Reset	Really Reset?			
	Colour System Reset	Really Reset?			
	Dimmer/Strobereset	Really Reset?			
	Zo.Fo.Fr.Reset	Really Reset?			
	Other Reset	Really Reset?			
Config Settings	DMX Channel Mode	Short Mode			
		Standard Mode			
		Extended Mode			
		View Selected Mode			
	Lamp Control	Lamp Control		OFF/ON	
		On By Power On		OFF/ON	
		Control By DMX		OFF/ON	
		Lamp Power		1200/1400	
	Signal Select	XLR Only			
		XLR First			
		Wireless Only			
		Wireless First			
		Wireless In/XLR Out			
		ARTNET Only			
		ARTNET/XLR Out			
		sACN Only			
		sACN In/XLR Out			
		Loss of DMX	Normal time out		
	Hold Last Value				
	Display Config	Display Mode		Off After Delay	
			On Always		

		Display Invert	Invert OFF	
			Invert ON	
			Invert Auto	
		Language Setting	English	
			Chinese	
	Temperature Unit	Touch Calibration	Input Password123	
		Celsius Degree		
	Un-Link Wireless	Fahrenheit Degree		
	Factory Defaults	Really Un-Link?		
Restore Defaults?				
Option Settings	Pan/Tilt Settings	Pan DMX Invert	OFF/ ON	
		Tilt DMX Invert	OFF/ ON	
		Pan Tilt Swap	OFF/ ON	
		XY Feedback	OFF/ ON	
		Pan/Tilt mode	Speed/Time	
	Invert Settings	Dimmer Invert	OFF/ ON	
		Zoom Invert	OFF/ ON	
		CMY Invert	OFF/ ON	
		CTO Invert	OFF/ ON	
Dimmer Curve	Linear/ Square Law			
Fan Mode	Standard/Theatre			
Defaults	Restore Defaults?			
Information	View DMX Values			
	Lamp Hours	Total Hours=xxxH Reset Lamp Hours		
	Total Hours	Total Hours=xxxH		
	Temperature	Display Board XX°C/F		
		Pan and Tilt XX°C/F		
		Driver Board 1 XX°C/F		
		Driver Board 2 XX°C/F		
		Driver Board 3 XX°C/F		
		Framing Board XX°C/F		
		Fan BoardXX°C/F		
	Head Sensor XX°C/F			
	Software Version	Display Board	System= XXX Boot =XXX	
		Pan and Tilt	System= XXX Boot =XXX	
		Driver Board 1	System= XXX Boot =XXX	
		Driver Board 2	System= XXX Boot =XXX	
		Driver Board 3	System= XXX Boot =XXX	
		Framing Board	System= XXX Boot =XXX	
		Fan Board	System= XXX Boot =XXX	
	Electronic SN	Electronic SN= *****		

	RDM Device Label	RDM Device Label PR-6000 W/F1400W Updated ANSI E1.20 RDM		
	Fan Status			
	XY Encoder			
	Lamp Fan Error			
Service	Manual Effect Control	Strobe XXX		
		Dimmer XXX		
		...		
	Factory Test			
Operation Mode	DMX 模式 DMX Mode	Change Operation Mode?		
	Master Mode	Preset Memory	Change Operation Mode?	
		User Memory 1	Change Operation Mode?	
		User Memory 2	Change Operation Mode?	
	Stand-Alone Mode	Preset Memory	Change Operation Mode?	
		User Memory 1	Change Operation Mode?	
		User Memory 2	Change Operation Mode?	
Static Scene	Change Operation Mode?			
User Memories	Edit User Memory	Edit User Memory 1 / Edit User Memory 2	Scene XX (1~200 Scenes)	Strobe XXX
				Dimmer XXX
				...
				Delay Time XXX
				Delay Unit
				Link To Step XXX
	Init User Memory	Edit Static Scene	Strobe XXX	
			Dimmer XXX	
			...	
			Reset User Memory 1	Reset User Memory?
Reset User Memory 2	Reset User Memory?	Input Password123		
Reset Static Scene	Reset Static Scene?	Input Password123		

7.DMX PROTOCOL

Short mode	Standard mode	Extended mode	Function Description	Decimal Low	Decimal High	Short mode
1	1	1	Strobe			
			Close (Lamp power is 1000W 5s after the strobe flags are closed)	0	10	
			Open	11	25	
			Strobe from slow to fast	26	225	
			Strobe Macro (Random strobe from fast to slow)	226	246	
			Open	247	255	
2	2	2	Dimmer			
			Close	0	0	
			(0-100%) linear dimmer	1	255	
	3	3	Dimmer in 16 bit			
			Dimmer fine	0	255	
3	4	4	CMY macros			
			The following functions will disable CMY,CTO, color wheel1 and color wheel2			

No function	0	7	
Color macro1	8	9	
Color macro2	10	11	
Color macro3	12	13	
Color macro4	14	15	
Color macro5	16	17	
Color macro6	18	19	
Color macro7	20	21	
Color macro8	22	23	
Color macro9	24	25	
Color macro10	26	27	
Color macro11	28	29	
Color macro12	30	31	
Color macro13	32	33	
Color macro14	34	35	
Color macro15	36	37	
Color macro16	38	39	
Color macro17	40	41	
Color macro18	42	43	
Color macro19	44	45	
Color macro20	46	47	
Color macro21	48	49	
Color macro22	50	51	
Color macro23	52	53	
Color macro24	54	55	
Color macro25	56	57	
Color macro26	58	59	
Color macro27	60	61	
Color macro28	62	63	
Color macro29	64	65	
Color macro30	66	67	
Color macro31	68	69	
Color macro32	70	71	
Color macro33	72	73	
Color macro34	74	75	
Color macro35	76	77	
Color macro36	78	79	
Color macro37	80	81	
Color macro38	82	83	
Color macro39	84	85	
Color macro40	86	87	
Color macro41	88	89	
Color macro42	90	91	
Color macro43	92	93	

Color macro44	94	95	
Color macro45	96	97	
Color macro46	98	99	
Color macro47	100	101	
Color macro48	102	103	
Color macro49	104	105	
Color macro50	106	107	
Color macro51	108	109	
Color macro52	110	111	
Color macro53	112	113	
Color macro54	114	115	
Color macro55	116	117	
Color macro56	118	119	
Color macro57	120	121	
Color macro58	122	123	
Color macro59	124	125	
Color macro60	126	127	
Color macro61	128	129	
Color macro62	130	131	
Color macro63	132	133	
Color macro64	134	135	
Color macro65	136	137	
Color macro66	138	139	
Color macro67	140	141	
Color macro68	142	143	
Color macro69	144	145	
Color macro70	146	147	
Color macro71	148	149	
Color macro72	150	151	
Color macro73	152	153	
Color macro74	154	155	
Color macro75	156	157	
Color macro76	158	159	
Color macro77	160	161	
Color macro78	162	163	
Color macro79	164	165	
Color macro80	166	167	
Color macro81	168	169	
Color macro82	170	171	
Color macro83	172	173	
Color macro84	174	175	
Color macro85	176	177	
Color macro86	178	179	
Color macro87	180	181	

			Color macro88	182	183	
			Color macro89	184	185	
			Color macro90	186	187	
			Color macro91	188	189	
			Color macro92	190	191	
			Color macro93	192	193	
			Color macro94	194	195	
			Color macro95	196	197	
			Color macro96	198	199	
			CMY color mixing from slow to fast	200	255	
4	5	5	Cyan			
			Linear cyan (0-100%)	0	255	
		6	Cyan in 16 bit			
			Cyan fine	0	255	
5	6	7	Yellow			
			Linear yellow(0-100%)	0	255	
		8	Yellow in 16 bit			
			Yellow fine	0	255	
6	7	9	Magenta			
			Linear magenta (0-100%)	0	255	
		10	Magenta in 16 bit			
			Magenta fine	0	255	
7	8	11	CTO			
			Linear CTO from high to low	0	255	
		12	CTO in 16 bit			
			CTO fine	0	255	
8	9	13	Color wheel 1			
			Continual positioning			
			Indexing 0-360°	0	63	
			Positioning			
			White/Color1(Red)	64	67	
			Color1(Red)	68	71	
			Color1(Red)/ Color2(Yellow)	72	75	
			Color2(Yellow)	76	79	
			Color2(Yellow)/ Color3(Blue)	80	83	
			Color3(Blue)	84	87	
			Color3(Blue) Color4(Green)	88	91	
			Color4(Green)	92	95	
			Color4(Green)/ Color5(Pink)	96	99	
			Color5(Pink)	100	103	
			Color5(Pink)/ Color6(Orange)	104	107	
			Color6(Orange)	108	111	
Color6(Orange)/ Color7(UV)	112	115				
Color7(UV)	116	119				

			Color7(UV)/White	120	123	
			White	124	127	
			Clockwise rainbow effect from slow to fast	128	191	
			Anti-clockwise rainbow effect from slow to fast	192	255	
	10	14	Color wheel1 in 16bit			
			Color wheel1 continual positioning in 16 bit	0	255	
9	11	15	Color wheel 2			
			Continual positioning			
			Indexing 0-360°	0	63	
			Positioning			
			White/Color1(Dark Red)	64	67	
			Color1(Dark Red)	68	71	
			Color1(Dark Red) / Color2(Dark Magenta)	72	75	
			Color2(Dark Magenta)	76	79	
			Color2(Dark Magenta)/ Color3(Light Magenta)	80	83	
			Color3(Light Magenta)	84	87	
			Color3(Light Magenta) Color4(Light Yellow)	88	91	
			Color4(Light Yellow	92	95	
			Color4(Light Yellow / Color5(Light Green)	96	99	
			Color5(Light Green)	100	103	
			Color5(Light Green)/ Color6(Dark cyan)	104	107	
			Color6(Dark cyan)	108	111	
			Color6(Dark cyan)/ Color7(Light Cyan)	112	115	
			Color7(Light Cyan)	116	119	
			Color7(Light Cyan)/White	120	123	
			White	124	127	
Clockwise rainbow effect from slow to fast	128	191				
Anti-clockwise rainbow effect from slow to fast	192	255				
	12	16	Color wheel2 in 16bit			
			Color wheel2continual positioning in 16 bit	0	255	
10	13	17	Framing blade 1left			
			Linear Framing Blade1 Left Change 0%-100%	0	255	
		18	Framing Blade 1 Left change in 16 bit			
			Framing Blade 1 Left change in 16 bit precision	0	255	
11	14	19	Framing Blade 1 Right			
			Linear Framing Blade1 Right Change 0%-100%	0	255	
		20	Framing Blade 1 Right change in 16 bit			
			Framing Blade 1 Right change in 16 bit precision	0	255	

12	15	21	Framing Blade 2 Left			
			Linear Framing Blade2 Left Change 0%-100%	0	255	
		22	Framing Blade 2 Left change in 16 bit			
			Framing Blade 2 Left change in 16 bit precision	0	255	
13	16	23	Framing Blade 2 Right			
			Linear Framing Blade2 Right Change 0%-100%	0	255	
		24	Framing Blade 2 Right change in 16 bit			
			Framing Blade 2 Right change in 16 bit precision	0	255	
14	17	25	Framing Blade 3 Left			
			Linear Framing Blade3 Left Change 0%-100%	0	255	
		26	Framing Blade 3 Left change in 16 bit			
			Framing Blade 3Left change in 16 bit precision	0	255	
15	18	27	Framing Blade 3 Right			
			Linear Framing Blade3 Right Change 0%-100%	0	255	
		28	Framing Blade 3 Right change in 16 bit			
			Framing Blade 3 Right change in 16 bit precision	0	255	
16	19	29	Framing Blade 4 Left			
			Linear Framing Blade4Left Change 0%-100%	0	255	
		30	Framing Blade 4 Left change in 16 bit			
			Framing Blade 4Left change in 16 bit precision	0	255	
17	20	31	Framing Blade 4 Right			
			Linear Framing Blade4Right Change 0%-100%	0	255	
		32	Framing Blade 4 Right change in 16 bit			
			Framing Blade 4 Right change in 16 bit precision	0	255	
18	21	33	Framing Module continual rotation			
			Framing Module Indexing(0-360degrees)	0	127	
			Stop	128		
			Framing Module forward rotation from slow	129	188	











			to fast			
			Stop	189	195	
			Framing Module reverse rotation from slow to fast	196	255	
		34	Framing Module continual rotation in 16 bit			
			Framing Module continual rotation in 16 bit	0	255	
19	22	35	Frost			
			Linear frost 0% - 100%	0	255	
20	23	36	Focus			
			Linear focus	0	255	
	24	37	Focus in 16 bit			
			Focus fine	0	255	
21	25	38	Zoom			
			Linear zoom	0	255	
	26	39	Zoom in 16 bit			
			Zoom fine	0	255	
22	27	40	Pan			
			Pan movement	0	255	
23	28	41	Pan in 16 bit			
			Pan movement in 16 bit	0	255	
24	29	42	Tilt			
			Tilt movement	0	255	
25	30	43	Tilt in 16 bit			
			Tilt movement in 16 bit	0	255	
26	31	44	Pan & Tilt speed			
			Time mode	0	1	
			Speed mode (speed from fast to slow)	2	255	
27	32	45	Special function			
			No function	0	4	
			Reserved	5	19	
			The following function must stay in the DMX range for more than 5s to activate it			
			2.The lamp can be turned off 5minutes after it is on, And the lamp can be turned on 5 minutes after it is off.			
			3.to turn on or turn off the lamp, keep lamp control-DMX control signal as ON			
			Display on	20	24	
			Display off	25	29	
			Reserved	30	34	
			Lamp power 1000W	35	39	
			Lamp power 1400W	40	44	
			Reserved	45	46	

		Fan standard mode	47	48	
		Fan theatre mode	49	50	
		Reserved	51	89	
		Pan and tilt speed mode	90	94	
		Pan and tilt time mode	95	99	
		Reserved	100	129	
		Lamp on	130	139	
		Pan and tilt reset	140	149	
		Color system reset	150	159	
		Reserved	160	169	
		Dimmer/ strobe reset	170	179	
		Zoom/focus/frost reset	180	189	
		Others(Framing module)reset	190	199	
		Total reset	200	209	
		Reserved	210	229	
		Lamp off	230	239	
		Reserved	240	255	



Remark:

1. The projector can't be turned on within 5 minutes after the lamp-off.
2. Fan error can cause lamp-off
3. "Speed Mode" means Pan and Tilt will move from Point A to Point B at their respective maximum speeds."Time Mode" means both Pan and Tilt will arrive at designated point at the same time. It's advised Time Mode be used if the projector runs circles or in oblique lines.

8.SIGNS ON THE DISPLAY

	Lamp Control		Option Settings
	Chinese/English		Information
	Error Messages		Service
	Address		Operation Mode
	Reset		User Memories
	Config Settings		

9.ERROR MESSAGE

The system can detect some errors during the reset, if  displayed, touch  to view the error. The error messages are as follows:

Name	Type	Correction
Pan	Timeout/magnet Sensor/Encoder	Check if wiring, positioning parts and motors are normal
Tilt	Timeout/magnet Sensor/Encoder	Check if wiring, positioning parts and motors are normal
Cyan	Timeout/magnet Sensor	Check if wiring, positioning parts and motors are normal
Yellow	Timeout/magnet Sensor	Check if wiring, positioning parts and motors are normal
Magenta	Timeout/magnet Sensor	Check if wiring, positioning parts and motors are normal
CTO	Timeout/magnet Sensor	Check if wiring, positioning parts and motors are normal
Color Wheel 1	Timeout/magnet Sensor	Check if wiring, positioning parts and motors are normal
Color Wheel 2	Timeout/magnet Sensor	Check if wiring, positioning parts and motors are normal
Dimmer	Timeout	Check if wiring and power supply are normal
Framing module rotation	Timeout/magnet Sensor	Check if wiring, positioning parts and motors are normal
Focus	Timeout/magnet Sensor	Check if wiring, positioning parts and motors are normal
Zoom	Timeout/magnet Sensor	Check if wiring, positioning parts and motors are normal
Lamp Fan1	Error	Check if fan and its wiring are normal
Lamp Fan2	Error	Check if fan and its wiring are normal
Head Fan1	Error	Check if fan and its wiring are normal
Strobe Fan	Error	Check if fan and its wiring are normal
Head Fan2	Error	Check if fan and its wiring are normal
CMY Fan	Error	Check if fan and its wiring are normal
Base Fan	Error	Check if fan and its wiring are normal
Pan and Tilt Board	Error	Check if signal wire and power supply are normal
Driver Board 1	Error	Check if signal wire and power supply are normal
Driver Board 2	Error	Check if signal wire and power supply are normal
Driver Board 3	Error	Check if signal wire and power supply are normal
Fan Board	Error	Check if signal wire and power supply are normal
Framing Module Board	Error	Check if signal wire and power supply are normal
Lamp on	Timeout	Check if the lamp is damaged
Lamp Life	Timeout/Warning	
Lamp Off[Fan Error]	Error	Check if all fans are normal
Time IC	Error	

10. TECHNICAL DATA

ELECTRICAL PARAMETER

Input voltage 200V~240V AC, 50/60Hz

Input power 1800W@220V

Power Factor: PF > 0.9

Specifications of light source (with 1400W ballast and igniter)

Osram Lok-it 1400/PS

Color temperature 6000K

CRI 90
Ceramic stand single-ended
Rated life 750hrs

COLORS

CMY color mixing with macros

2 color wheels: each with 7 colors+ open

Half color effect, bi-directional rotation with varied speeds for rainbow effect

Stepping/Linear color changing

Color wheel 1

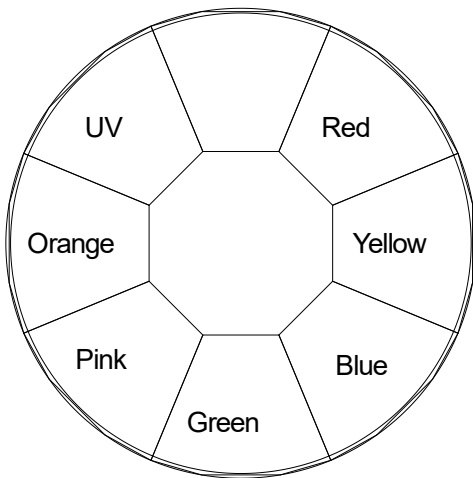

Color wheel2

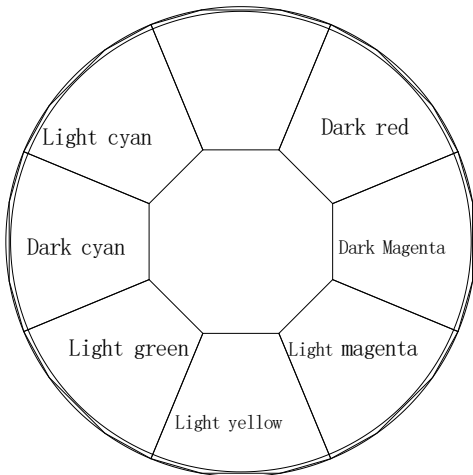

CTO

0-100% linear CTO system

FOCUS

DMX linear focus

DIMMER

0-100% linear adjustment

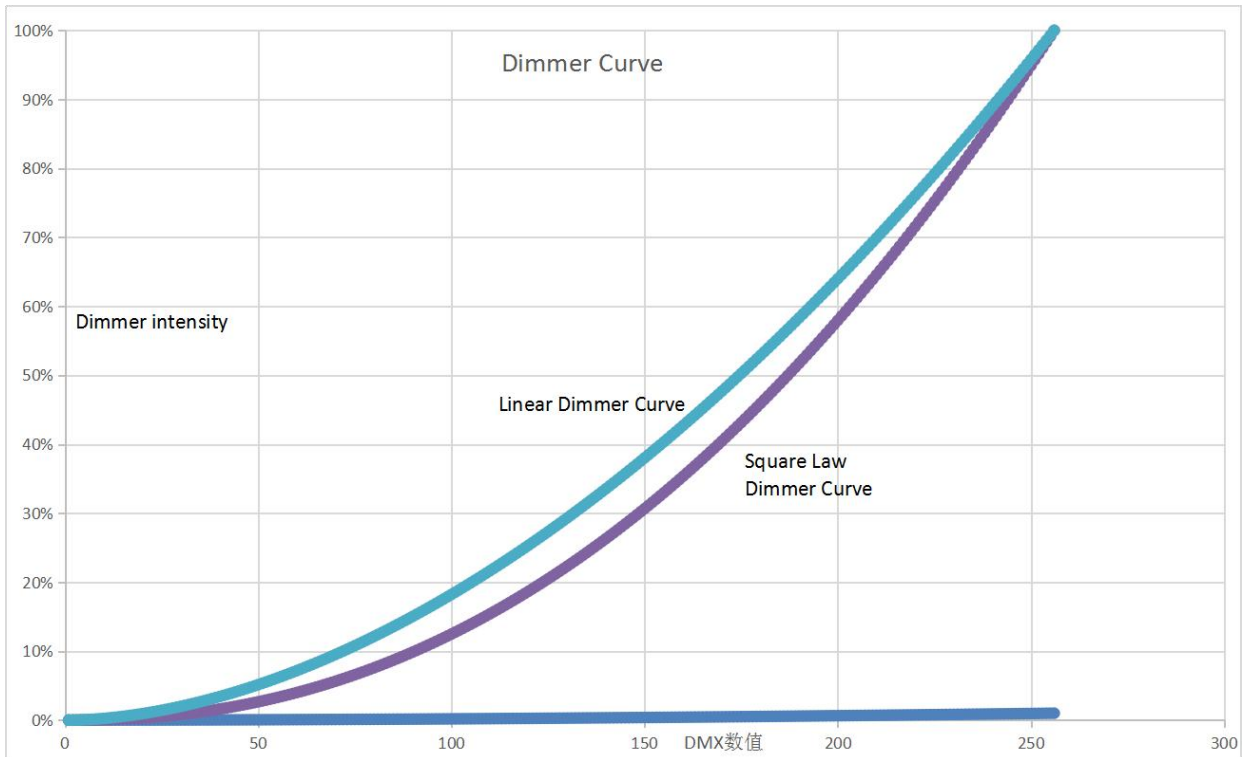

STROBE

Double shutter blades, 0.3~25 F.P.S

HEAD MOVEMENT

Pan 540°, Tilt 270° with auto position correction

BEAM ANGLE

linear zoom 10°~ 60°with 16 bit function

CONTROL

DMX512, 3 pin and 5 pin interfaces

RMD control protocol

27channels in short mode, 32channels in standard mode and 45channels in extended mode

Self-test mode

OTHER FUNCTIONS

Adjustable Pan & Tilt speed

Lamp and Total hours displayed

LCD English and Chinese Display with Contrast and brightness adjustable

Energy saving ballast

Built-in sensor diagnostic system

Input signal isolation

Modular Structure for easy maintenance

Ethernet Interface

DMX512 wireless receiver

DMX512 Transmitter (Optional)

ArtNet and sACN (Optional)

HOUSING

High temperature ABS, IP20

NET WEIGHT

46Kg

OPERATION TEMPERATURE

Ambient temperature at maximum: 40°C

SIZES:(Unit: m m)

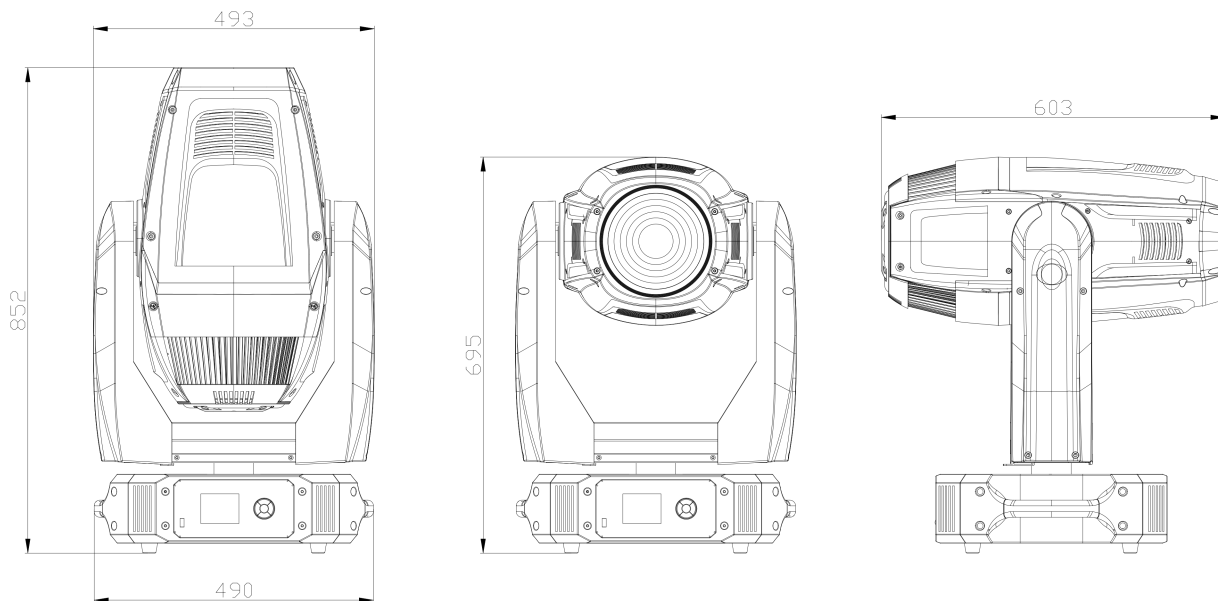

LIGHT OUTPUT

60° (lux)	0	2722	680	302	170	109	76
10° (lux)	0	84530	21132	9392	5283	3381	2348

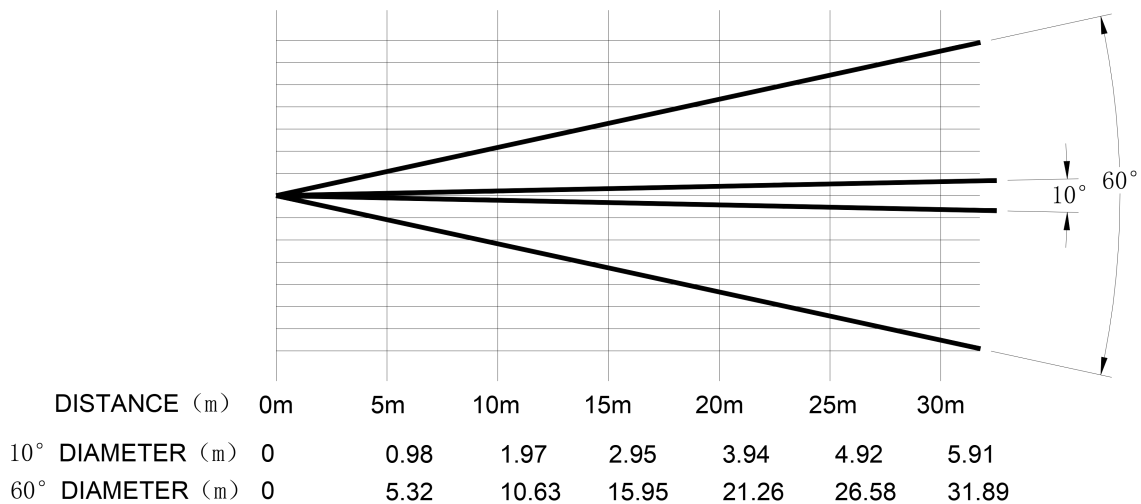

11.CIRCUIT DIAGRAM

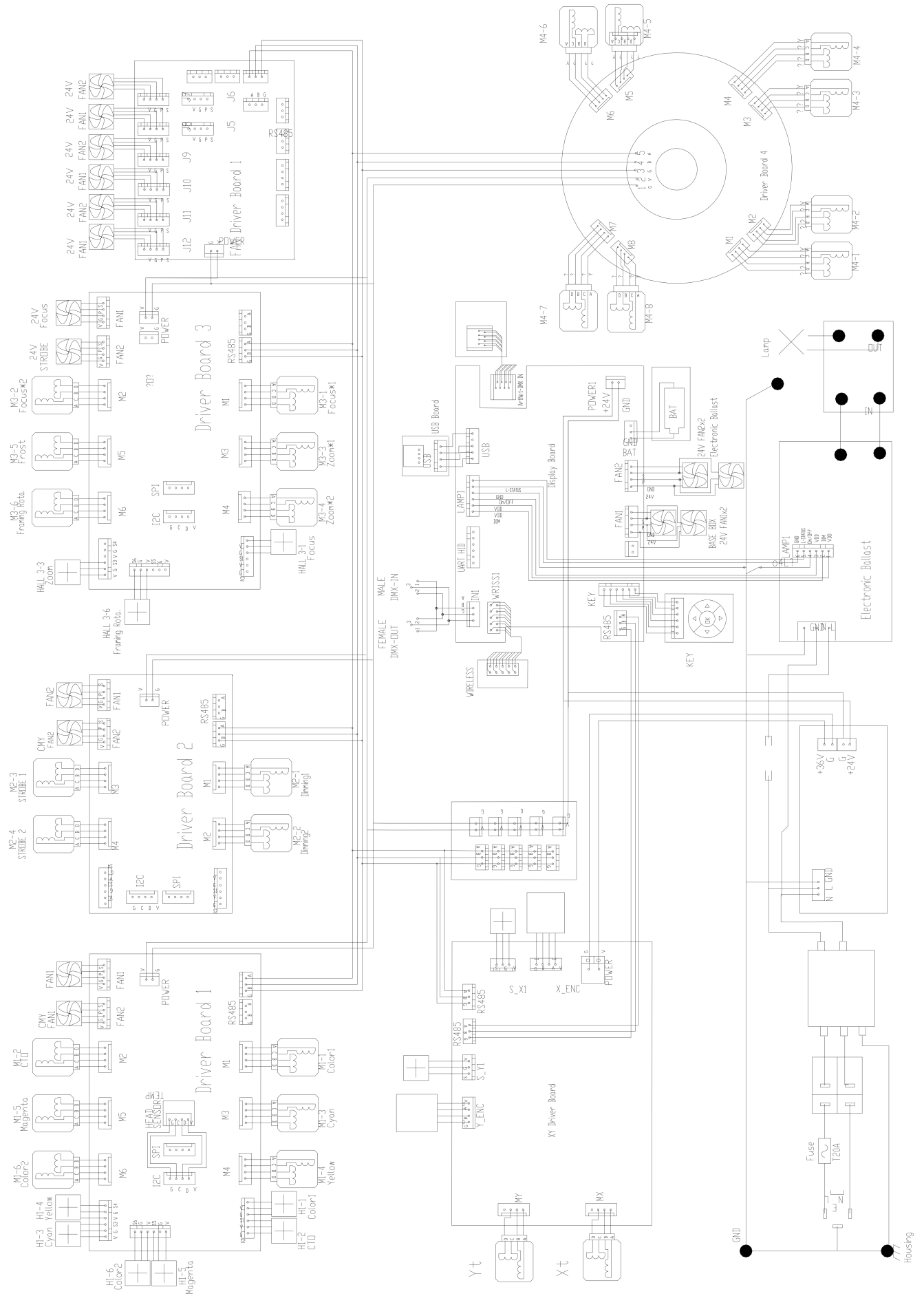

12.COMPONENT ORDER CODES

NAME	CODE NUMBER	QTY	REMARKS
SWITCHING POWER SUPPLY	230020689	1	
POWER FILTER	193020014	1	
THERMAL SWITCH	190010206	1	
ELECTRONIC BALLAST (1400W)	040070140	1	
LAMP (OSRAM 1400W)	100070047	1	Lok-it! 1400W/PS OSRAM
IGNITER(1400W)	040090066	1	
TILT BELT	290151205	1	
PAN BELT	290151207	1	
LAMP FAN1	030060117	2	
LAMP FAN2	030060119	2	
CHAMBER FAN	030060119	2	
STROBE FAN	030060117	1	
CMY FAN	030060119	2	
HEAD SIDE FAN	030060119	2	
BASE FAN	030060122	2	
BALLAST FAN	030069005	1	
FOCUS MOTOR	030040073	2	
ZOOM MOTOR	030040073	2	
PAN MOTOR	030040262	1	
TILT MOTOR	030040262	1	
STROBE MOTOR	030040214	2	
COLOR WHEEL MOTORS	030040214	2	
FROST MOTOR	030040248	1	
CYM MOTOR	030040114A	3	
CTO MOTOR	030040114A	1	
DIMMER MOTOR	030040093	2	
PAN AND TILT BOARD	230061269	1	
MASTER BOARD	230061268	1	
DRIVER BOARD1	230061270	1	
DRIVER BOARD2	230061271	1	
DRIVER BOARD3	230061272	1	
FAN CONTROL BOARD	230061273	1	
8CHANNEL BOARD FOR FRAMING MODULE	230061275	1	
ETHERNET CONVERTER	W012756	1	

Appendix: SOME ITEMS REQUIRING ATTENTION AS FOR THE USE OF DISCHARGE LAMP

For the effective extension of the lifespan of discharge lamp, some factors impacting its lifespan are specially listed below, based on manufacturing technology and working mechanism of discharge lamps., physical attributions of the lamps including lamp striking theory(ignited by focused high voltage---highly pressurized air broken down and burning---lamp on at high temperature with thermal protection--- stable running) and lamp off theory(lamp off power ---lamp off at high temperature and thermal protection-highly pressurized air vaporizing evenly---completion of lamp off.

1. The sequence of lamp striking: Power on→lamp striking by controller(advised not to strike lamp via power on), the sequence of lamp off: lamp off by controller→mains power shut off (advised not to turn off lamp by shutting off mains power)
2. Within 1 min after lamp striking, it shouldn't re-strike it frequently. ONLY more than 10 min after the projector is cooled after lamp off, can the lamp be re-stricken again.
3. Within 5 min after lamp striking, it can't be turned off. During the lamp striking process, it's forbidden to turn off lamp via shutting off mains power, but via controller. More than 5 min after the projector is cooled after lamp off, can the mains power be shut off.
4. The projector is advised not to point to the same point for long time, i.e., it shouldn't be used for long time at a fixed angle.
5. The projector is advised not to use double colors for long time, i.e., it shouldn't use 2 or more colors for long time.
6. The projector is advised not to keep shutters closed while lamp on for long time, i.e., it should be less than 1 hr after shutters closed after lamp on.
7. It is advised not to use lamp half power function for long time.

PR LIGHTING LTD.

1582 Xingye Avenue, Nancun Panyu
Guangzhou, 511442 China
TEL: +86-20-3995 2888

PR lighting will try its best to offer accurate and overall information about a product's technical data. Any changes won't be notified if necessary. Patented Products. Counterfeiting Will be Prosecuted!

P/N: 320021132A
Old Version:20250319
New Version:20250912