

## **AQUA LASER 260 BEAM**

**PR-8329**

The user manual contains important information about the safe installation and use of a projector. Please read and follow these instructions carefully and keep the manual in a safe place for future reference.

PR LIGHTING LTD.  
<http://www.pr-lighting.com>

## INDEX

1. SAFETY AND WARNINGS.....	3
2. INSTRUCTIONS.....	4
3. INSTALLATION.....	5
4. SETUP AND CONFIGURATION.....	7
5. OPERATION MENU.....	9
6. DMX PROTOCOL.....	12
7. ERROR MESSAGE.....	16
8. TECHNICAL DATA.....	16
9. CIRCUIT DIAGRAM.....	19
10. COMPONENT ORDER CODES.....	20

## ACCESSORIES

The following items are supplied with the projector and please check:

Name	Quantity	Unit	Remark
Safety cord	1	Pc	
User manual	1	Pc	

**Please note that as part of our ongoing commitment to continuous product development, specifications are subject to change without notice. Whilst every care is taken in the preparation of the manual we reserve the right to change specifications in the course of product improvement. The publishers cannot be held responsible for the accuracy of the information herein, or any consequence arising from them.**

**Every unit is tested completely and packed properly by the manufacturer. Please make sure the packing and / or the unit are in good condition before installation and use. Should there be any damage caused by transportation, consult your dealer and do not use the unit. Any damage caused by improper use will not be assumed by the manufacturer and / or dealer.**

**Note: For the products made by Guangzhou PR lighting Ltd, the warranty for the whole product is one year starting from the delivery date but the light source is not within the warranty.**







## 1. SAFETY AND WARNINGS



### NOTE

Before a projector's installation, power-on, operation and maintenance, please carefully read the safety information hereinafter!

The following safety signs are used in the user manual.

						
Warning	User Manual	Electrical shock	Goggles	Protective Gloves	Flames	High Temperature



- When unpacking, check if there is transportation damage before using a projector. Should there be any damage caused by transportation, consult your dealer and do not use it.
- The manufacturer is not responsible for any loss caused by the user not following the manual or changing a projector as he/she likes.
- Please be noted that the damage caused by changing a projector at will is not warranted.
- Do not hesitate to contact the dealer or the manufacturer if any questions or advice.
- If a lamp is damaged or deforms because of heat, it should be replaced. (It applies only to traditional lamps)



- The projector is for indoor and outdoor use, IP66.
- It can be used in humid and dusty areas. And it can contact water and other non-corrosive liquids.
- The projector should be kept away from high temperature, fire, electrical surge, vibration and strong light while being operated
- The projector is only intended for installation, operation and maintenance by qualified personnel. And the operation must strictly follow the procedures in the manual
- No repairable parts in the projector and do not open covers for maintenance by yourself.



- Don't look straightly into the light sources especially for epileptics, otherwise eyes will be burned. 
- Do not connect a projector to any type of dimmer pack.
- If the lamp, lens and screen protective cover of the a projector have obvious damage, i.e., to the extent that it hurts the performance like cracking or deformation. Please stop using it and replace them with the original parts, otherwise its performance will be compromised.
- For the installation location of a projector, it shouldn't be seen in the distance of less than 4 meters for a long time.



- Before operation, please confirm that all covers (housing) are on and screws tightened. It's forbidden to use a projector while covers (housing) are off.
- Keep the lamp clean and do not touch it with bare hands.
- While operating it, wear protective items like eye goggles, gloves and etc..



- Any electrical connection must be carried out by a qualified person.
- Before installation, please confirm the voltage supplied matches what is required for a projector.
- Each projector must be properly earthed and installed as per related electrical standards.
- Do not use power cord with its insulator damaged and connect the power cord with other cables.
- If a projector is not used or under cleaning, please hold the plug and unplug it. Do not unplug it forcefully or by pulling the power cable.

- All power cords must conform to related safety and regulations.
- If a projector is not water and dust proof, while being operated it should not be under rains or in humidity to avoid short circuit.
- Do not switch on and off a projector constantly in very short intervals, otherwise the light source's and other electrical parts' life will be shortened .



- There are safety cord holes at the bottom of the base of a projector. In view of safety, please run the safety cord supplied through the safety cord holes for safety support.
- Before any installation, maintenance and cleaning work, please ensure a projector is disconnected from power mains.



- While running normally under normal ambient temperature, the temperature of the external surface of the metal housing of a projector including that of the heat sink may reach 75°C at maximum.
- While the lamp is stricken for the first time, there will be smoke and strange smell. It's normal and does not mean a projector has some defects.

- While it running, don't touch the metal housing to avoid being burned!



- Do not mount a projector directly on inflammable surface.
- Do not project the beam straightly on combustible items and the minimum distance between a projector and illuminated items is 18m.
- A projector should be installed with good ventilation and the minimum distance between a projector and a wall is 50cm. At the same time, please ensure the fans and air inlets and outlets are workable.
- Do not let the front lens under sunlight or other strong light sources at any angle, otherwise the danger of fire can be caused by the focused beam by the lens inside a projector.



- The product meets The General Technical Requirements and Standards for Recycle and Use Of Expired Appliance and Electronic Products.
- When the product meets disposal standards and needs to be disposed, a client needs to dispose and recycle it.

## 2. INSTRUCTIONS

### ●CLEANING AND MAINTENANCE

Under normal running, the protective units of a projector should be inspected regularly like power fuse. If it is burned, please install a new one and ensure it is the same rating as the burned one. For a projector with an over-temperature protective unit, please inspect cooling units regularly like cooling fans, heat sink and other cooling parts. Please check if the fans run normally or fans and air inlets are blocked by dust. To keep air inlets /outlets clean, cooling fans should be cleaned every 15days.

For projectors with lens, reflectors and coated filters, the accumulation of oil, smoke and dust on them will compromise the light output. Cleaning a projector is very necessary to ensure a reliable use. Internal and external lens, flat glass, reflector and coated filters need to be cleaned periodically to optimize light output.

Cleaning frequency is to be decided by operations and its environment. Use soft cloth and normal detergent for glass for cleaning work. It's advised external optical system be cleaned every 20days and internal optical systems every 30/60days. For a projector with high IP rating, if no damage inside, it is advised to clean the surfaces of its housing in principle. Keep lens clean and do not touch optical parts with bare hands.

### SPECIAL NOTE:

It's normal phenomena that there will be mild water mist on the lens while the waterproof product is in use.



- Before any maintenance and cleaning, please ensure a project is off the power.
- Only a qualified person is allowed to do maintenance.



•To avoid sunlight or other light penetrating into the head via the front lens, resulting in high temperature internally causing damages to a projector. Before power-off, please use Tilt channel to move the head and make the head facing downward.

- Do not use alcohol or other organic solvent to clean the housing to avoid damage.
- Do not use any solvent with chemical elements to clean coated filters.

•LUBRICATION

To ensure smooth movement of gobos and zoom and focus lens, it's advised rotators' bearings and 2 sliding bars for zoom and focus lens be lubricated every 2 months. High quality and high temperature lubricant/grease is advised..

•TROUBLESHOOTING

PROBLEM	ACTION
A projector doesn't switch on	<ul style="list-style-type: none"> <li>➤ Check the fuse on the power socket.</li> <li>➤ Check the lamp.</li> </ul>
The lamp is on but a projector doesn't respond to the controller	<ul style="list-style-type: none"> <li>➤ Make sure that the fixture's start address is right</li> <li>➤ Replace or repair the XLR signal cable.</li> </ul>
A projector functions intermittently	<ul style="list-style-type: none"> <li>➤ Make sure the fan is working well or fans and their shields are not blocked</li> </ul>
Beam appears dim, Low in brightness	<ul style="list-style-type: none"> <li>➤ Make sure the lamp is within its lifespan</li> <li>➤ Remove dust or grease from the lenses.</li> </ul>
The project image appears to have a halo	<ul style="list-style-type: none"> <li>➤ Carefully clean the lamp, optical lenses and other components.</li> </ul>
Heavily Defective Beam	<ul style="list-style-type: none"> <li>➤ Check if lens are in good condition(not cracked)</li> <li>➤ Clean dust or grease on the lens.</li> </ul>

3. INSTALLATION

•RIGGING

Before moving a projector, Please lock Pan and Tilt. Before its operation, please unlock them. It's forbidden to run a projector with power while it is locked.

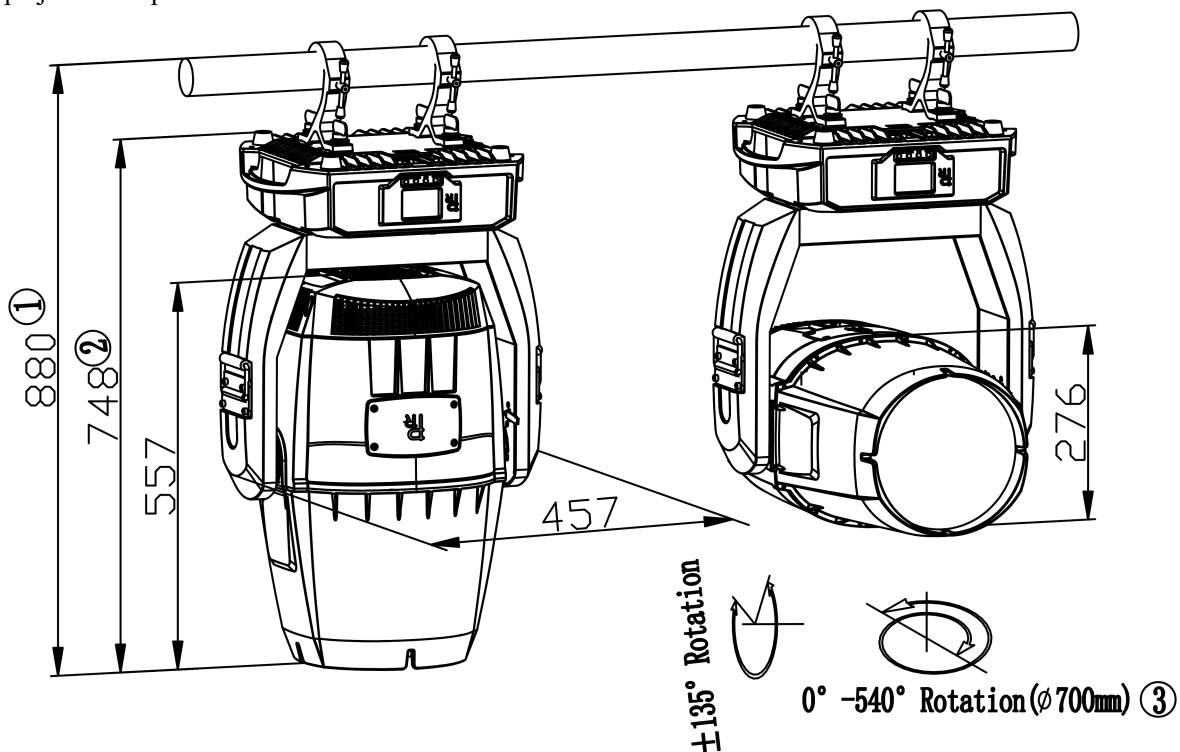

Remarks:

1. The distance between the top of the mounting bar and the top of the head;

2. The Distance between the top of the feet and the top the head;
3. The head's rotating diameter( the minimum distance between 2 neighboring projectors on the truss)

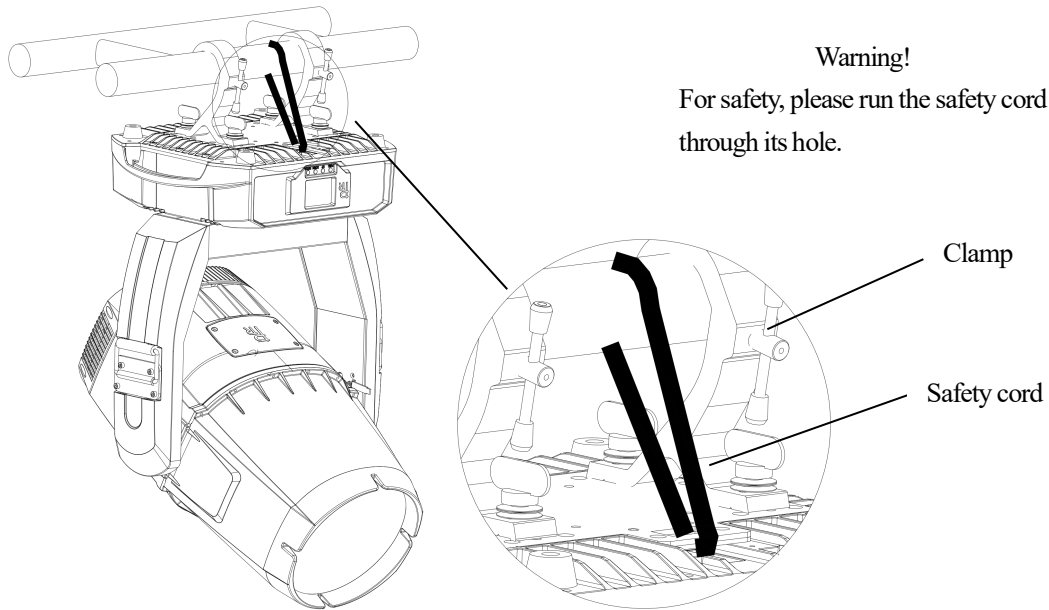

Take 2 clamps and the safety cord out from the package and mount 2 clamps on the underside of fixture with 2 retainers attached to each clamp. Hang the fixture on the structure and fasten the screws attached to each clamp. (See the **WARNING** on the underside of the base as shown above) **To pass the SAFETY CORD through the HOLES for safety!** Always ensure that the projector is firmly anchored to avoid vibration and slipping whilst functioning. Always ensure that the structure that you are going to mount the projector to is secure and strong enough to support the weight of a XR 1000 Framing.



**WARNING:**

- The projector **MUST** be lifted or carried by the **HANDLES** instead of clamps.
- For safety the safety cord should afford 10 times the Projector's weight.

**• POWER CONNECTION**

Connect the power cord as follows:

- L (live) =brown
- E (earth) =yellow/green
- N (neutral) =blue

Before power connection, please ensure the power supplied must match what the nameplate says. It is recommended that each projector be connected with power separately so that they may be individually switched on and off.



- The earth wire(yellow/green) must be connected to the ground. And electrical connection must be in accordance with the standards concerned.
- If any questions about the electrical installation, do not continue but consult a qualified electrician.

**•DMX CONTROL CONNECTION:**

Connection between controller and projector and between one projector and another must be made with a twin-screened cable, with each wire having at least a 0.5mm in diameter. Connection to and from the projector is via cannon 5 pin (which are included with the projector) or 5 pin XLR plugs and sockets. The XLR's are connected as shown in the figure above.

Note: care should be taken to ensure that none of the pins touch the metallic body of the plug or each other. XLR plugs and sockets mustn't be connected in any way other than mentioned in the above figure. The Fixture accepts digital control signals in protocol DMX512 (1990).

Connect the controller's DMX output to the first fixture's DMX input, and connect the first fixture's DMX output to the second fixture's DMX input and connect the rest fixtures in the same way. Eventually connect the last fixture's DMX output to a DMX terminator as shown in the figure below.

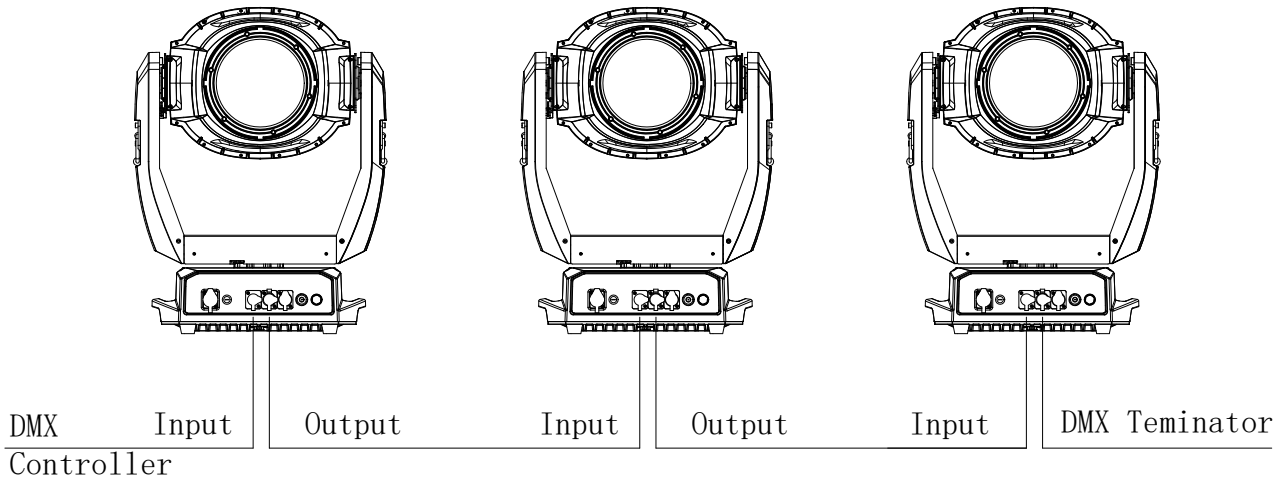

**DMX TERMINATOR**

In the Controller mode, at the last fixture in the chain, the DMX output has to be connected with a DMX terminator. This prevents electrical noise from disturbing and corrupting the DMX control signals.

The DMX terminator is simply an XLR connector with a 120Ω (ohm) resistor connected across pins 2 and 3, which is then plugged into the output socket on the last projector in the chain. The connections are illustrated below.

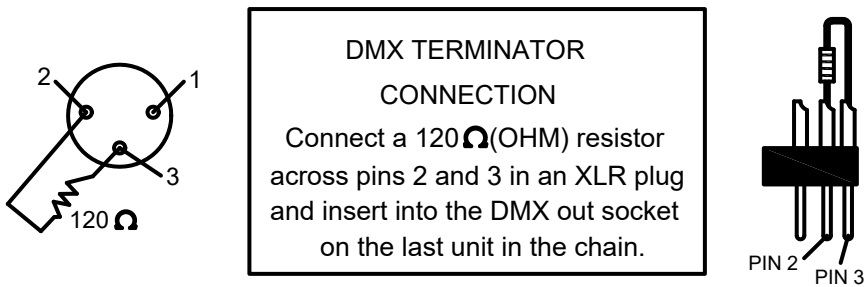

**4. SETUP AND CONFIGURATION**

**FRONT PANEL OPERATION**

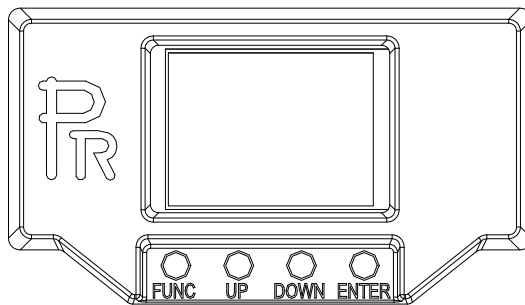

To browse through or change the projector's settings, press ENTER key for more than 3s (press ENTER key after power on) to unlock the screen, then press UP/DOWN key to enter the projector's function menus. Each main menu has its sub-menus. And each menu stands for special function. For the details, please see the following 6<sup>th</sup> point "Operation Menu".:

1. At the page to set the fixture's functions, press **UP** or **DOWN** key to select the functions desired.
2. While menu operations, the **FUNC** key to escape, and **ENTER** key is used to confirm. Press **ENTER** key to save the changes or enter into the sub menus. Press **UP** or **DOWN** key to change the numbers (minus or plus).

Press FUNC key to go to the upper menu. If no key is pushed, the system will go back to initial status automatically.

**• DMX START ADDRESS**

Each projector must be given a DMX start address so that the correct projector responds to the correct control signals. This DMX start address is the channel number from which the projector starts to “listen” to the digital control information being sent out from the controller. The projector has 3DMX modes. There are standard mode ,short mode and extended mode. For example standard mode has 17 channels, so set the No. 1 projector’s address 001, No. 2 projector’s address 018, No. 3 projector’s address 035, No. 4 projector’s address 052, and so on.

Switch on the Projector . Press **ENTER** key more than 3 seconds to unlock panel, then press **UP** or **DOWN** key to enter into the fixture’s operation menus.

Select DMX Address icon and press ENTER key on the display and select DMX address at the 2<sup>nd</sup> level menu for the address setting.

Press **UP** or **DOWN** key for the DMX address desired.

Press **ENTER** key to confirm.

Press the **FUNC** key to go back to the upper level menu.

**•DMX WIRELESS CONTROL(Only for fixtures with wireless control)**

The projector has wireless control function with wireless receiver module and antenna for remote control.

The setup of it is below:

1. Press **ENTER** for more than 3s to unlock the control panel, then press **UP** or **DOWN** key to enter into the operation menu and select “Config Settings”.
2. Select “Wireless Only” from the menu of “Signal Select”.

Only after the projector is linked with a transmitter, can it receive wireless signal sent by the transmitter. If unlinking it, Press “Enter” for the menu of Un-link Wireless under the upper level menu of Config Settigns , then the fixture is unlinked with the wireless transmitter.

**•STAND-ALONE MODE**

Operate the projector without connecting with a controller, enable the master mode through the operation panel, the projector will run in Stand-Alone mode automatically.

DMX address can be set at any number within 512.

**•MASTER/SLAVE MODE**



Many projectors can run synchronously in the Master/Slave mode by linking them with each other. First, connect the first fixture’s DMX output to the second fixture’s DMX input using XLR-XLR control cable and then connect the second fixture’s DMX output to the third fixture’s DMX input, and so on until all projector are connected in this way. Eventually connect the last fixture’s DMX output to a DMX terminator. Set 1<sup>st</sup> projector as the master and others are Slaves.

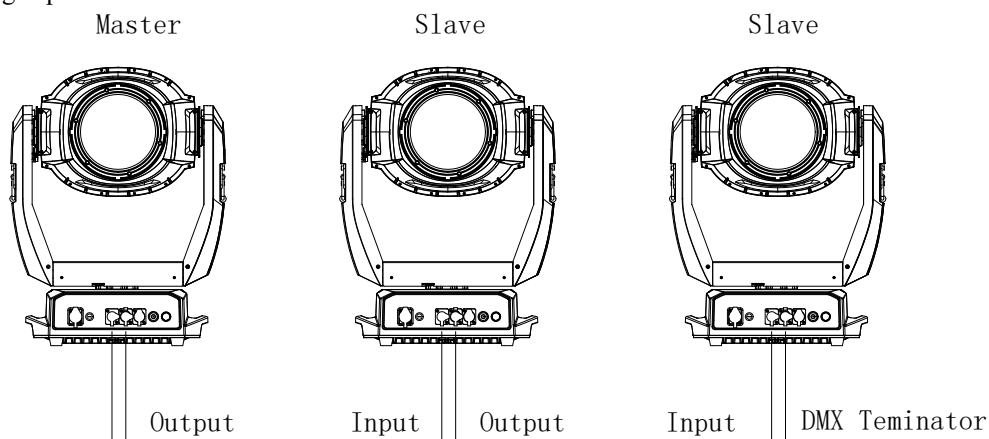

Start Addresses of all Slaves are 001; Operation mode of the Master can be set any mode for a Master’ and Slaves’ operation mode can be set accordingly.



After Powered on, the group will run in Master/Slave Mode



## 5. OPERATION MENU

1st LEVEL	2nd LEVEL	3rd LEVEL	4th LEVEL	5th LEVEL	
Address 	DMX Address	1-498(Short Mode) 1-496(Standard Mode) 1-495(Extend Mode)			
	IP Address	Default IP Address	2.X.X.X/10.X.X.X		
		Custom IP Address	X.X.X.X		
	SubNet Mask	X.X.X.X			
	ArtNet ArtNet Universe	0-255			
sACN universe	1-63999				
Reset 	Total Reset	Really Reset? Confirm or Cancel			
	Pan&Tilt Reset	Really Reset? Confirm or Cancel			
	Colour System Reset	Really Reset? Confirm or Cancel			
	Gobo Reset	Really Reset? Confirm or Cancel			
	Fo. Pr. Reset	Really Reset? Confirm or Cancel			
Config Settings 	DMX Channel Mode	Short Mode 15CH			
		Standard Mode 17CH			
		Extended Mode 18CH			
		View Selected Mode	Ch.01 Strobe Ch.02 Dimmer ... Ch. XX control function		
	Signal Select (Only for fixtures with wireless control)	XLR Only			
		XLR First			
		Wireless Only			
		Wireless First			
		Wireless In/XLR Out			
		Artnet Only			
		Artnet In/XLR Out			
		sACN only			
	sACN/XLR				
Loss of DMX	Normal time out				

		Hold Last Value		
	Display Config	Display Mode	Off After Delay	
			On Always	
		Display Invert	Invert OFF	
			Invert ON	
			Invert Auto	
	Language Setting	English/Chinese		
	Temperature Unit	Celsius Degree		
		Fahrenheit Degree		
	Un-Link Wireless (Only for fixtures with wireless control)	Really Un-Link? Confirm or Cancel		
	Factory Defaults	Restore Defaults? Confirm or Cancel		
Option Settings  	Pan/Tilt Settings	Pan DMX Invert	OFF/ ON	
		Tilt DMX Invert	OFF/ ON	
		Pan Tilt Swap	OFF/ ON	
		XY Feedback	OFF/ ON	
		Pan/Tilt mode	Speed/Time	Note: "Speed Mode" means Pan and Tilt will move from Point A to Point B at their respective maximum speeds. "Time Mode" means both Pan and Tilt will arrive at designated point at the same time. It's advised Time Mode be used if the projector runs circles or in oblique lines.
	Dimmer Settings	Dimmer Speed	Fast/Medium/Slow Speed	
Information  	View DMX Values	Channel Value Strobe XXX Dimmer XXX Dimmer Fine XXX Color Wheel XXX FixedGoboWheelXXX Prism 1 XXX Prism 1 Rotation XXX		

		Prism 2 XXX Prism 2 Rotation XXX Focus XXX Pan XXX Tilt XXX ControlFunction XXX		
	Lamp Hours	Lamp Hous=XXX H Reset Lamp Hours		
	Total Hours	Total Hous ××××H		
	Temperature	Display Board=×××C Pan board=×××C Tilt board=×××C Motor driver board1=×××C Motor driver board2=×××C Light source driver board =×××C Light source=×××C		
	Software Version	Display Board xxx xxx Pan board xxx xxx Tilt board xxx xxx Motordriverboardxxx xxx Lightsourcedriverboard xxx xxx		
	Electronic SN	XXXXXXX		
	RDM Device Label	ANSI E1.20 RDM		
	Fan Status	Fan Speed RSpeed Base fan xxx on/off Lens fan xxx on/off Head fan xxx on/off Lightsourcefanxxx on/off		
	Lamp Fan Error	Base fan xxx Lens fan xxx Head fan xxx Lightsource fan xxx		
 Service	Manual Effect Control	Channel Value Strobe XXX Dimmer XXX Color Wheel XXX  FixedGobo Wheel XXX Prism1 XXX Prism 1 Rotation XXX Prism 2 XXX Prism 2 Rotation XXX Focus XXX Pan XXX Tilt XXX		
	Factory Mode	XXX		
 Operation Mode	DMX Mode	Change Operation Mode? Confirm or Cancel		
	Master Mode	Preset Memory	Change Operation Mode? Confirm or Cancel	
User Memory 1		Change Operation Mode? Confirm or Cancel		

		User Memory 2	Change Operation Mode? Confirm or Cancel	
	Stand-Alone Mode	Preset Memory	Change Operation Mode? Confirm or Cancel	
		User Memory 1	Change Operation Mode? Confirm or Cancel	
		User Memory 2	Change Operation Mode? Confirm or Cancel	
	Static Scene	Change Operation Mode? Confirm or Cancel		
User Memories 	Edit User Memory	Edit User Memory 1 / Edit User Memory 2	(1~200Scenes) Scene XX (1~200 Scenes)	Strobe XXX Dimmer XXX ColorWheel XXX FixedGoboWheelXX Rot.GoboWheelXXX Prism1 XXX Prism1Rotation XXX Prism2 XXX Prism2Rotation XXX Focus XXX Pan XXX Tilt XXX Hold time XXX DelayTime XXX Delaytimeunit ms/s/m LinktoStep XXX
		Edit Static Scene	Paste? Confirm or Cancel	Strobe XXX Dimmer XXX ColorWheel XXX FixedGoboWheelXX Rot.GoboWheelXXX Prism1 XXX Prism1Rotation XXX Prism2 XXX Prism2Rotation XXX Focus XXX Pan XXX Tilt XXX
	Init User Memory	Reset User Memory 1	Reset User Memory? Confirm or Cancel	
		Reset User Memory 2	Reset User Memory? Confirm or Cancel	
		Reset Static Scene	Reset Static Scene? Confirm or Cancel	

## 6. DMX PROTOCOL

Short mode	Standard Mode S	Extended Mode E	FUNCTION	DMX	DESCRIPTION
1	1	1	Strobe	000-010	Close
				011-025	Open
				026-225	Strobe speed from slow to fast
				226-246	Random strobe from slow to fast
				247-255	Open
2	2	2	Dimmer	000-255	Linear dimming (0-100%)
	3	3	Dimmer Fine	000-255	Dimmer in 16 bit
3	4	4	Color Wheel	000-063	Indexing(0-360degrees)
				064-067	Open
				068-070	Color1

				071-073	Color2
				074-076	Color3
				077-079	Color4
				080-082	Color5
				083-085	Color6
				086-088	Color7
				089-091	Color8
				092-094	Color9
				095-097	Color10
				098-100	Color11
				101-103	Color12
				104-106	Color13
				107-109	Color14
				110-112	Color15
				113-115	Color16
				116-118	Color17
				119-121	Color18
				122-124	Color19
				125-127	Open
				128-191	Rotation ,Clockwise from slow to fast
				192-255	Rotation, Anti-clockwise from fast to slow
	5	5	Color Wheel Fine	0000-255	Color Wheel in 16 Bit
4	6	6	Fixed Gobo Wheel	0-11	Open
				12-15	Gobo1
				16-19	Gobo2
				20-23	Gobo3
				24-27	Gobo4
				28-31	Gobo5
				32-35	Gobo6
				36-39	Gobo7
				40-43	Gobo8
				44-47	Gobo9
				48-51	Gobo10
				52-55	Gobo11
				56-59	Gobo12
				60-63	Gobo13
				64-67	Gobo14
				68-71	Gobo15
				72-75	Gobo16
				76-79	Gobo17
				80-83	Gobo18
				84-87	Gobo19
				88-91	Gobo20
				92-95	Gobo21



				96-99	Gobo22
				100-103	Gobo23
				104-107	Gobo24
				108-111	Gobo25
				112-115	Gobo26
				116-119	Gobo27
				120-123	Gobo28
				124-127	Gobo29
				128-149	Clockwise rotation from slow to fast
				150-171	Anti Clockwise rotation from slow to fast
				172-174	Shake effect 1 from slow to fast
				175-177	Shake effect 2 from slow to fast
				178-180	Shake effect 3 from slow to fast
				181-183	Shake effect 4 from slow to fast
				184-186	Shake effect 5 from slow to fast
				187-189	Shake effect 6 from slow to fast
				190-192	Shake effect 7 from slow to fast
				193-195	Shake effect 8 from slow to fast
				196-198	Shake effect 9 from slow to fast
				199-201	Shake effect 10 from slow to fast
				202-204	Shake effect 11 from slow to fast
				205-207	Shake effect 12 from slow to fast
				208-210	Shake effect 3 from slow to fast
				211-213	Shake effect14 from slow to fast
				214-216	Shake effect 15 from slow to fast
				217-219	Shake effect 16 from slow to fast
				220-222	Shake effect 17 from slow to fast
				223-225	Shake effect 18 from slow to fast
				226-228	Shake effect19 from slow to fast
				229-231	Shake effect20 from slow to fast
				232-234	Shake effect21 from slow to fast
				235-237	Shake effect 22 from slow to fast
				238-240	Shake effect 23 from slow to fast
				241-243	Shake effect24 from slow to fast
				244-246	Shake effect25 from slow to fast
				247-249	Shake effect 26 from slow to fast
				250-252	Shake effect27 from slow to fast
				253-255	Shake effect 28 from slow to fast
5	7	7	Prism 1	000-016	Open
				017-127	Prism1
				128-255	Prism2
6	8	8	Prism1 Rotation	000-127	Prism Indexing
				128	Stop
				129-191	Rotation(Clockwise from slow to fast)

				192	Stop
				193-255	Rotation(Anti- Clockwise from slow to fast)
7	9	9	Prism 2	000-016	White
				017-127	Prism3
				128-255	Frost in
8	10	10	Prism2 Rotation	000-127	Prism2 Indexing
				128	Stop
				129-191	Rotation(Clockwise from slow to fast)
				192	Stop
				193-255	Rotation(Anti- Clockwise from slow to fast)
9	11	11	Focus	000-255	Linear focus
		12	Focus Fine	000-255	Focus in 16 bit precision
10	12	13	Pan	000-255	Pan(0°~540°)
11	13	14	Pan Fine	000-255	Pan in 16 bit
12	14	15	Tilt	000-255	Tilt(0°~270°)
13	15	16	Tilt Fine	000-255	Tilt in 16 bit
14	16	17	Pan & Tilt Speeds	000-255	Pan & Tilt Speed from Fast to Slow
15	17	18	Control	000-019	Reserved
				Keep in the DMX range for more than 5S to activate the following functions. If power-off, the following are invalid.	
				020-024	Graphic Display On
				025-029	Graphic Display Off
				030-052	Reserved
				053-054	Diming speed fast
				055-056	Diming speed Medium
				057-058	Diming speed slow
				059-089	Reserved
				090-094	Pan & Tilt Speed Mode
				095-099	Pan & Tilt Time Mode
				100-139	Reserved
				140-149	Pan & Tilt Reset
				150-159	Color System Reset
				160-169	Gobo Wheel Reset
				170-179	Dimmer/Shutter Reset
				180-189	Focus/Prism Reset
				190-199	Reserved
				200-209	Total Reset
				210-255	Reserved

**Remarks:**

1. Fan error can cause lamp-off.
2. Note: "Speed Mode" means Pan and Tilt will move from Point A to Point B at their respective maximum speeds."Time Mode" means both Pan and Tilt will arrive at designated point at the same time. It's advised Time Mode be used if the projector runs circles or in oblique lines.

## 7. ERROR MESSAGES

The system can detect some errors during the reset, if  displayed, touch  to view the error.  
The error messages are as follows:

Name	Type	Correction
Pan	Timeout/magnet Sensor/Encoder	Check if wiring, positioning parts and motors are normal
Tilt	Timeout/magnet Sensor/Encoder	Check if wiring, positioning parts and motors are normal
Color Wheel	Timeout	Check if wiring, positioning parts and motors are normal
Fixed gobo wheel	Timeout	Check if wiring, positioning parts and motors are normal
Dimmer	Timeout	Check if wiring, positioning parts and motors are normal
Prism	Timeout	Check if wiring, positioning parts and motors are normal
Prism Rotation	Timeout	Check if wiring, positioning parts and motors are normal
Focus	Timeout	Check if wiring, positioning parts and motors are normal
Fan	Error	Check if fan and its wiring are normal
Pan Board	Error	Check signal wire
Tilt Board	Error	Check signal wire
Motor Driver Board	Error	Check signal wire
Light source driver board		
Acceleration Sensor	Error	Check signal wire
Lamp on	Timeout	Check if the lamp is damaged
Lamp Life	Timeout Warning	
Lamp Off[Fan Error]	Error	Check if all fans are normal
Time IC	Error	

## 8. TECHNICAL DATA

### Electric parameters

Input voltage: 100V~240V AC, 50/60Hz  
 Power consumption: 390W @ 220V  
 Rated current: 1.8A @ 220V  
 Power factor: PF>0.9

### Light sources

Light sources 260W laser module  
 Color temperature 9000K  
 Rated life 12000hrs

### Colors

1 color wheel: 19 colors + open  
 Macros and bi-directional rainbow effects with variable speeds

### Fixed gobo wheel

1 fixed gobo wheel: 30 gobos+ open

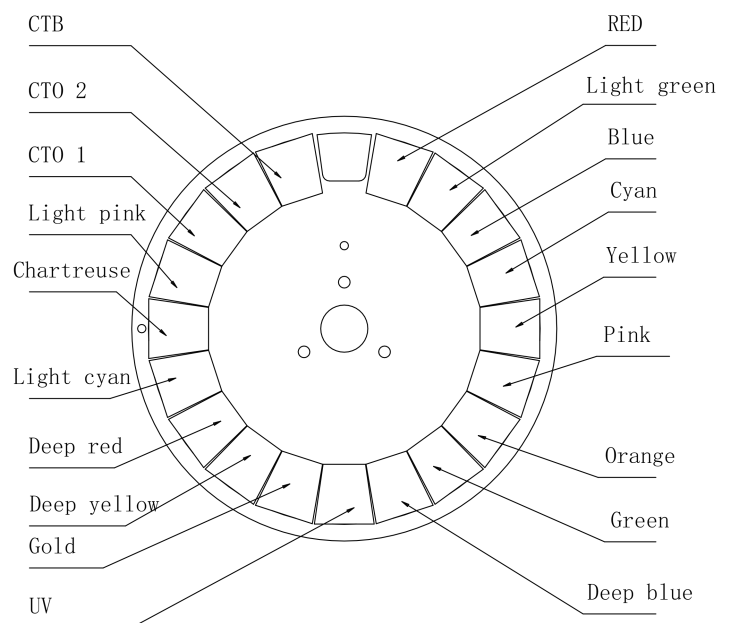

Shakable at variable speeds and bi-directional rotation at variable speeds

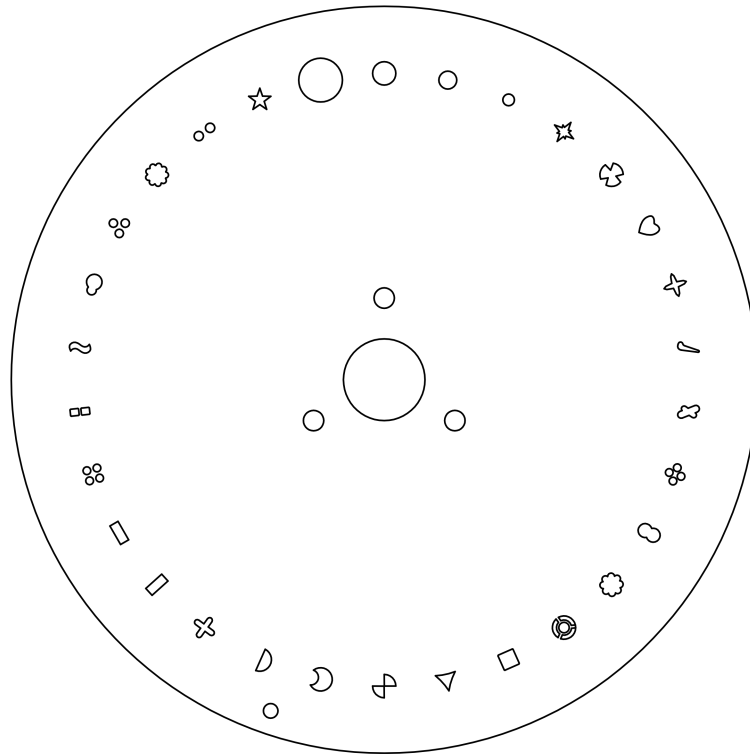

**Prism/frost:**

3 prism wheels: (a 8-facet circular prism+ a 4-facet linear prism )+ (a 16-facet circular prism + a frost filter), Other prism options available.

**Focus**

DMX linear focus

**Strobe/dimmer**

Double flag strobe, 0.3-25 F.P.S. / linear dimmer

**Movements**

Pan (0°-540°), Tilt( 0°-270°) with auto positioning correction function

**Beam angle**

Beam angle: 0.8°

**Control**

International standard DMX 512 signal,5-pin XLR connectors

Short Mode 15 channels, standard Mode 17channels,extended mode 18channels

Self test mode

**Other functions**

Pan and Tilt speeds adjustable

Lamp hours and fixture hours displayed

Modular construction easy for maintenance

Wireless receiver

Wireless transmitter (Optional)

ArtNet and sACN (Optional)

### Housing and ingress protection

Cast aluminum and high temperature and UV resistant ABS with IP66

### Weight

Net weight: 37.6Kg

### Ambient temperature

-20 °C ~ 45 °C

Note: If a fixture runs with the ambient temperature below 0 Celsius, it should be heated for some time(less than 20 minutes based on actual conditions) before turning on the laser module.

### Sizes (unit: mm)

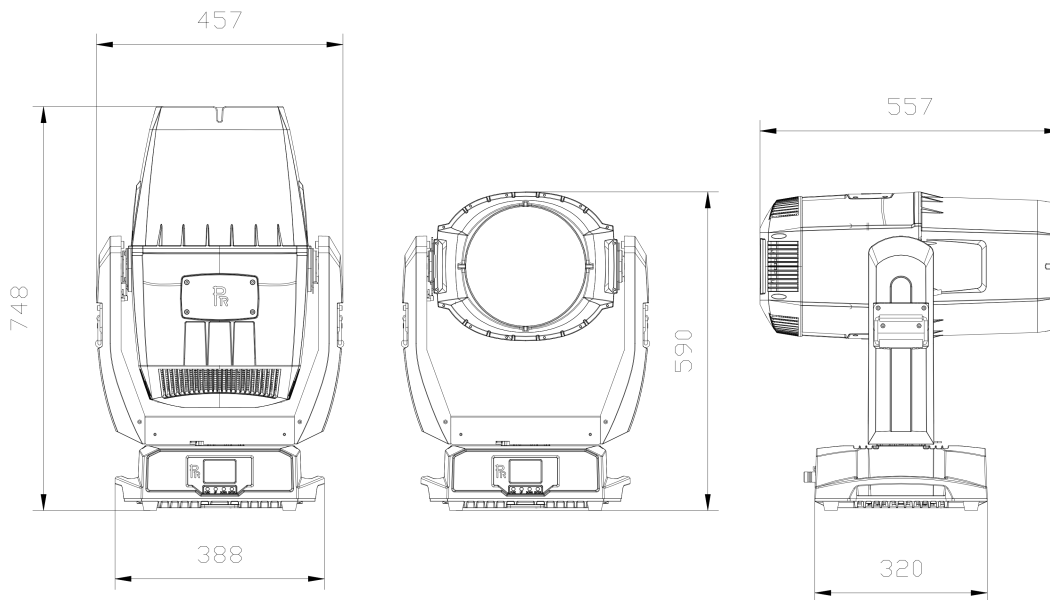

### Light output

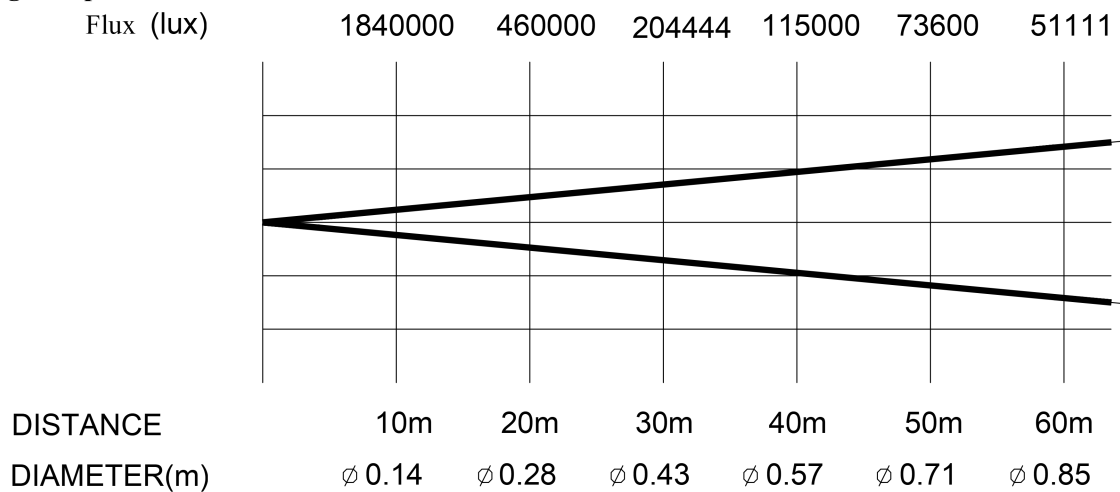

# 9. CIRCUIT DIAGRAM

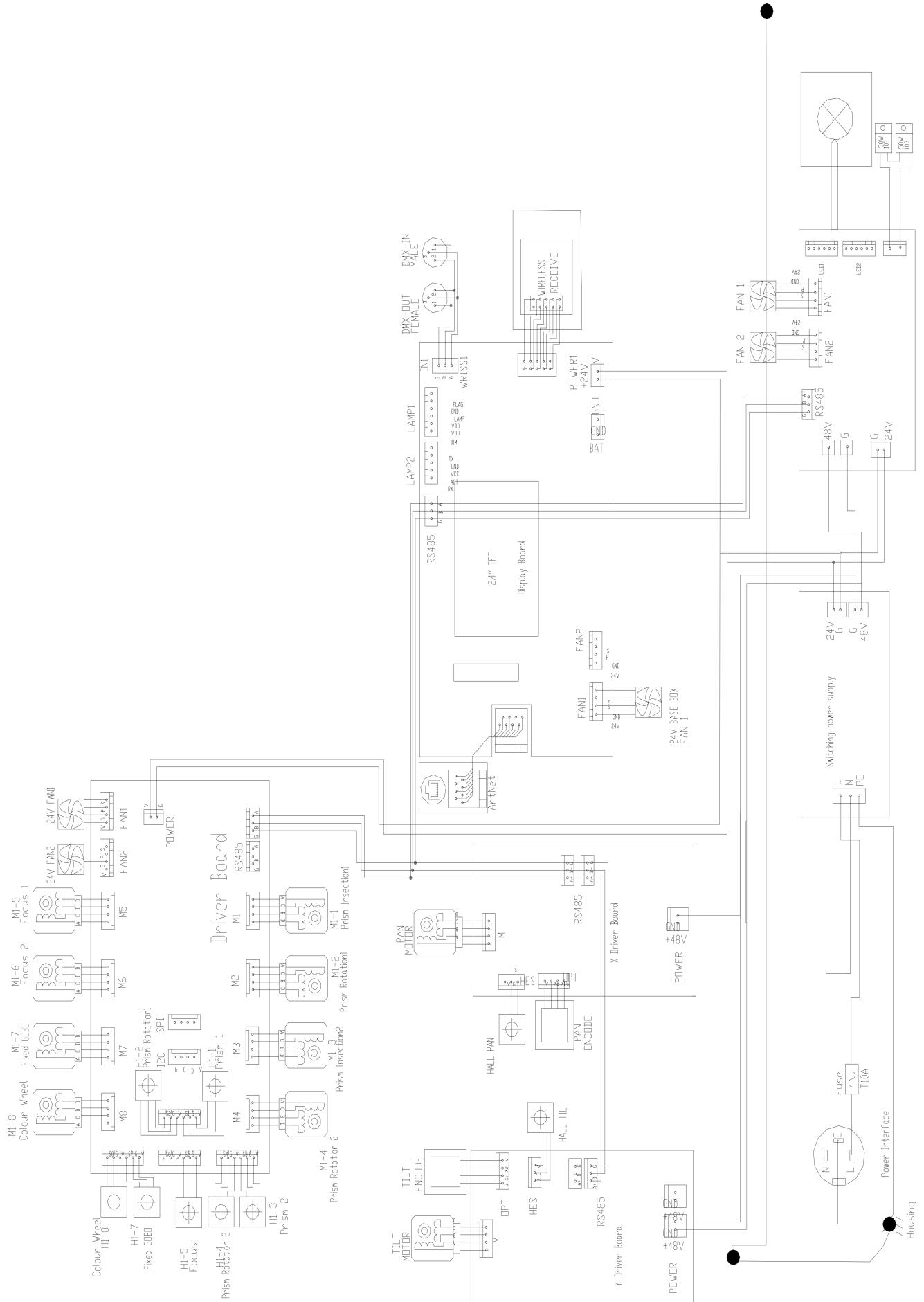

**10. COMPONENT ORDER CODES**

<b>NO</b>	<b>NAME</b>	<b>CODE NUMBER</b>	<b>QTY</b>
SWITCHING POWER SUPPLY	192010237	1	
LIGHT SOURCE	150020339	1	
HEAD FAN	030060116	1	
CHAMBER FAN	030060117	1	
LENS FAN	030060106	1	
LIGHT SOURCE FAN	030060121	1	
BASE FAN	030060075	1	
PAN MOTOR	030040246B	1	
TILT MOTOR	030040278B	1	
FOCUS MOTOR	030040243A	2	
FIXED GOBO MOTOR	030040221C	1	
COLOR WHEEL MOTOR	030040221C	1	
PRISM IN/OUT MOTOR	030040221C	2	
PRISM ROTATION MOTOR	030040254	2	



PR LIGHTING LTD.

---

1582 Xingye Avenue, Nancun Panyu  
Guangzhou, 511442 China  
TEL: +86-20-3995 2888

---

PR lighting will try its best to offer accurate and overall information about a product's technical data. Any changes won't be notified if necessary. Patented Products.  
Counterfeiting Will be Prosecuted!

P/N: 320021423  
Old Version: 20230919  
New Version: 20240424